

Practice Problems on Bernoulli's Equation

bernoulli_01

A person holds their hand out of a car window while driving through still air at a speed of V_{car} . What is the maximum pressure on the person's hand?

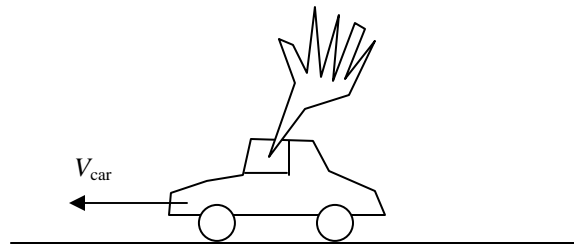

Answer(s):

$$p_0 = p_{\text{max}} = p + \frac{1}{2} \rho V_{\text{car}}^2$$

Practice Problems on Bernoulli's Equation

bernoulli_02

Water is siphoned from a large tank through a constant diameter hose as shown in the figure. Determine the maximum height of the hill, H_{hill} , over which the water can be siphoned without cavitation occurring. Assume that the vapor pressure of the water is p_v , the height of the water free surface in the tank is H_{tank} , and the vertical distance from the end of the hose to the base of the tank is H_{end} .

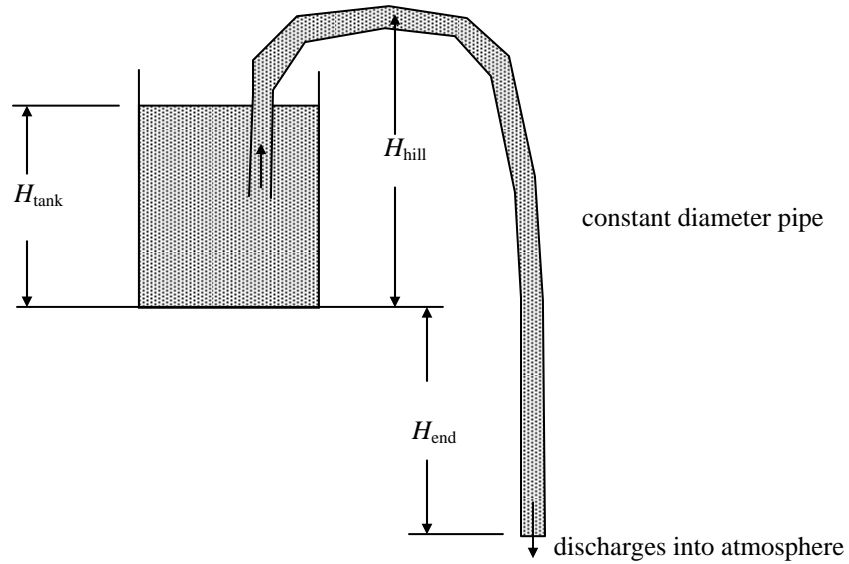

Answer(s):

$$H_{\text{hill}} = \frac{p_{\text{atm}} - p_v}{\rho g} - H_{\text{end}}$$

Practice Problems on Bernoulli's Equation

bernoulli_03

Air flows through the Venturi tube that discharges to the atmosphere as shown in the figure. If the flow rate is large enough, the pressure in the constriction will be low enough to draw the water up into the tube. Determine the flow rate, Q , needed to just draw the water into the tube. What is the pressure at section 1? Assume the air flow is frictionless.

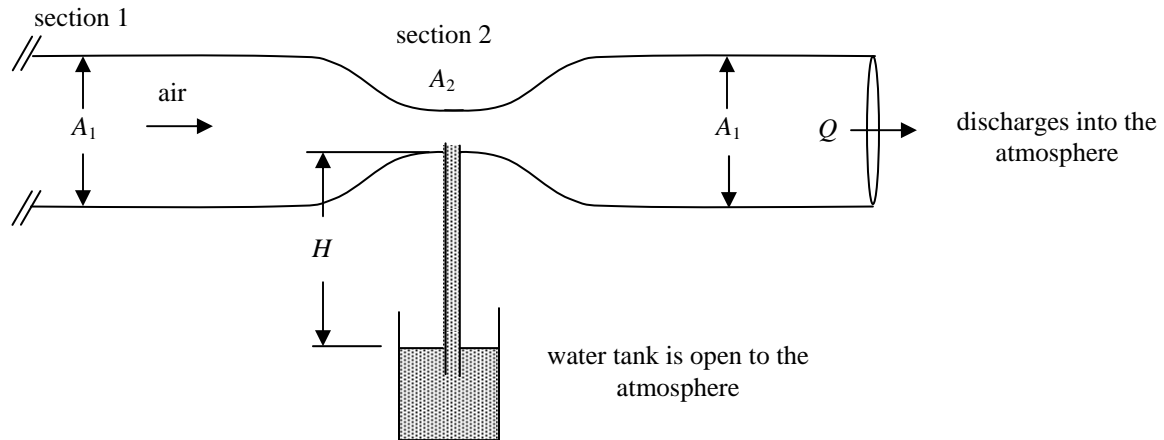

Answer(s):

$$Q = \sqrt{2gH \left(\frac{\rho_{\text{H}_2\text{O}}}{\rho} \right) \left(\frac{1}{A_2^2} - \frac{1}{A_1^2} \right)^{-1}}$$

$$p_A = p_C = p_{\text{atm}}$$

Practice Problems on Bernoulli's Equation

bernoulli_05

You are to design Quonset huts for a military base. The design wind speed is $U_\infty = 30$ m/s and the free-stream pressure and density are $p_\infty = 101$ kPa and $\rho_\infty = 1.2$ kg/m³, respectively. The Quonset hut may be considered to be a closed (no leaks) semi-cylinder with a radius of $R = 5$ m which is mounted on tie-down blocks as shown in the figure. The flow is such that the velocity distribution over the top of the hut is approximated by:

$$u_r(r = R) = 0$$

$$u_\theta(r = R) = -2U_\infty \sin \theta$$

The air under the hut is at rest.

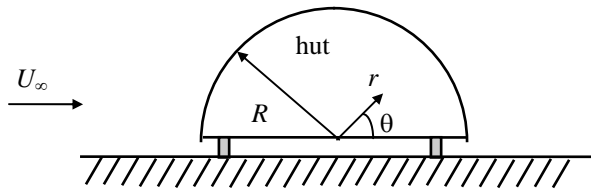

- What is the pressure distribution over the top surface of the Quonset hut?
- What is the net lift force acting on the Quonset hut due to the air? Don't forget to include the effect of the air under the hut.
- What is the net drag force acting on the hut? (Hint: A calculation may not be necessary here but some justification is required.)

Answer(s):

$$C_{p, \text{top}} = \frac{P_{\text{surface}} - P_\infty}{\frac{1}{2} \rho U_\infty^2} = 1 - 4 \sin^2 \theta$$

$$C_L = \frac{L}{\frac{1}{2} \rho U_\infty^2 (2R)} = \frac{8}{3}$$

$$\therefore D = 0$$

Practice Problems on Bernoulli's Equation

bernoulli_06

An air cushion vehicle is supported by forcing air into the chamber created by a skirt around the periphery of the vehicle as shown. The air escapes through the 3 in. clearance between the lower end of the skirt and the ground (or water). Assume the vehicle weighs 10,000 lb_f and is essentially rectangular in shape, 30 by 50 ft. The volume of the chamber is large enough so that the kinetic energy of the air within the chamber is negligible. Determine the flowrate, Q , needed to support the vehicle.

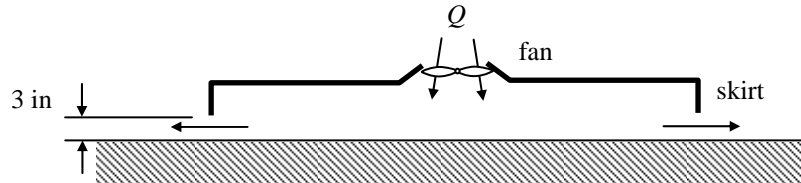

Answer(s):

$$Q = \sqrt{\frac{2WA_{\text{skirt}}^2}{\rho A_{\text{projected}}}}; \quad Q = 2990 \text{ ft}^3/\text{s}$$

Practice Problems on Bernoulli's Equation

bernoulli_07

Oil flows through a contraction with circular cross-section as shown in the figure below. A manometer, using mercury as the gage fluid, is used to measure the pressure difference between sections 1 and 2 of the pipe.

Assuming frictionless flow, determine:

- the pressure difference, $p_1 - p_2$, between sections 1 and 2, and
- the mass flow rate through the pipe.

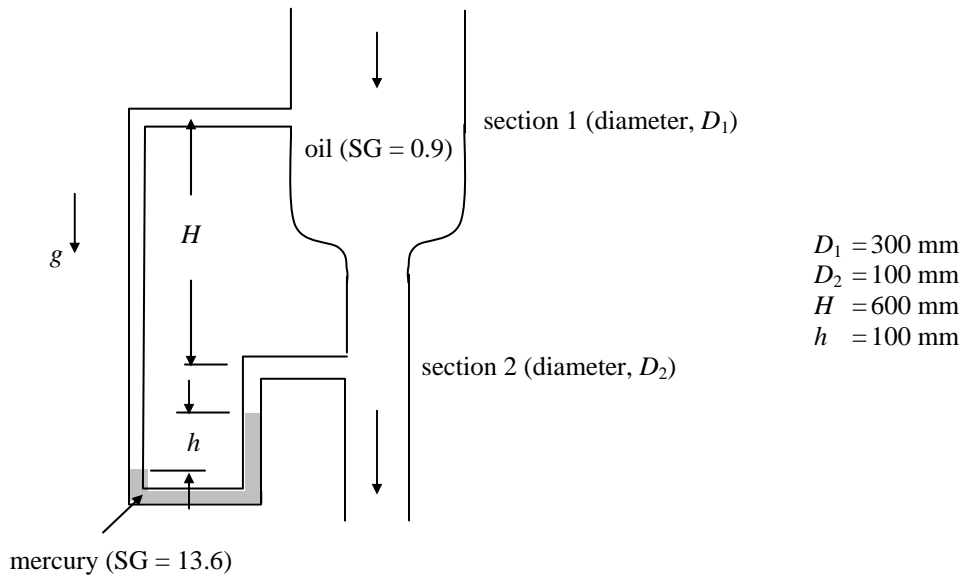

Answer(s):

$$p_1 - p_2 = \rho_{\text{Hg}} g [SG_{\text{Hg}} h - SG_{\text{oil}} (H + h)]$$

$$\dot{m}_{\text{oil}} = \rho_{\text{oil}} Q = \rho_{\text{oil}} \sqrt{\frac{\pi^2 g}{8} \left(\frac{D_1^4 D_2^4}{D_2^4 - D_1^4} \right) \left(\frac{p_2 - p_1}{\rho_{\text{oil}} g} - H \right)}$$

Practice Problems on Bernoulli's Equation

bernoulli_08

A lightweight card of mass, m , can be supported by blowing air at volumetric flow rate, Q , through a hole in a spool as shown in the figure. The spool and card have diameter, D , and the spool has a large cavity with diameter, d .

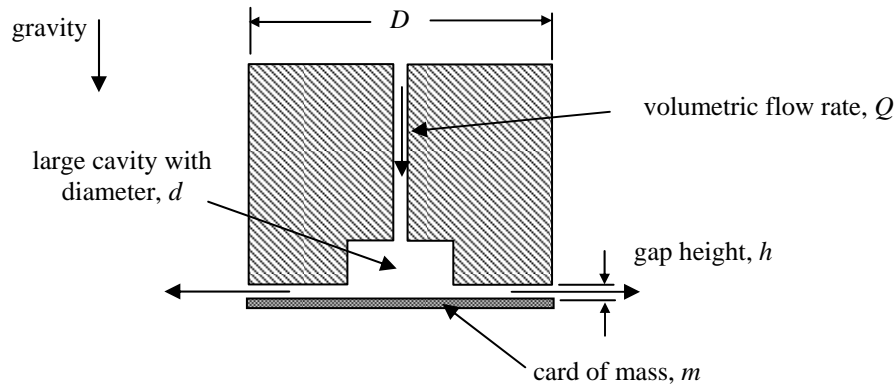

- Determine the relationship between volumetric flow rate, Q , and the gap height, h . Clearly state all significant assumptions.
- Would the radial pressure gradient in the gap be greater for a viscous or an inviscid flow? Justify your answer.

Answer(s):

$$h = Q \sqrt{\frac{\rho \left[2 \ln \left(\frac{D}{d} \right) - 1 \right]}{8\pi m g}}$$

Practice Problems on Bernoulli's Equation

bernoulli_09

If the approach velocity is not too large, a hump of height, H , in the bottom of a water channel will cause a dip of magnitude Δh in the water level. This depression in the water can be used to determine the flow rate of the water. Assuming no losses and that the incoming flow has a depth, D , determine the volumetric flow rate, Q , as a function of Δh , H , D , and g (the acceleration due to gravity).

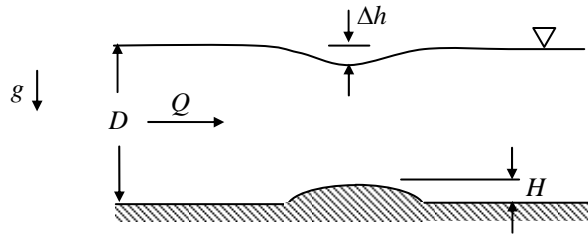

Answer(s):

$$\therefore Q = \sqrt{\frac{2g\Delta h}{\left(\frac{1}{D-H-\Delta h}\right)^2 - \left(\frac{1}{D}\right)^2}}$$

Practice Problems on Bernoulli's Equation

bernoulli_10

In which of the following scenarios is applying the following form of Bernoulli's equation:

$$\frac{p}{\rho g} + \frac{V^2}{2g} + z = \text{constant}$$

from point 1 to point 2 valid?

a.

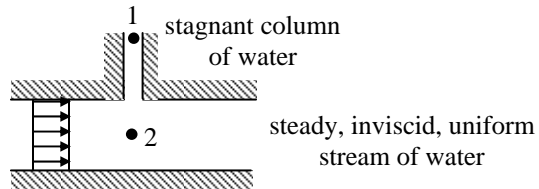

b.

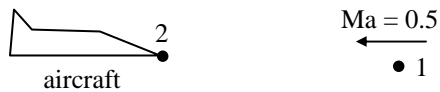

c.

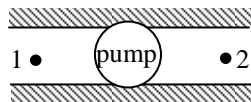

d.

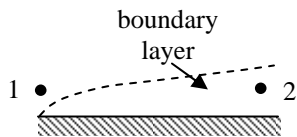

e.

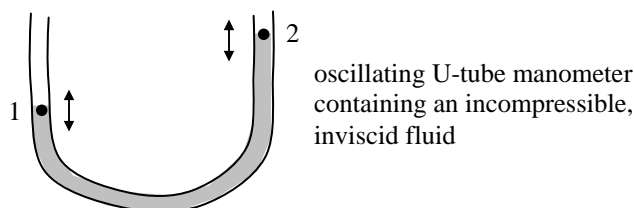

Answer(s):
Not provided.

Practice Problems on Bernoulli's Equation

bernoulli_12

The device shown in the figure below is proposed for measuring the exhalation pressure and volume flow rate of a person. A circular tube, with inside radius R , has a slit of width w running down the length of it (a cut-out in the cylinder). Inside the tube is a lightweight, freely moving piston attached to a linear spring (with spring constant k). The equilibrium position of the piston is at $x = 0$ where the slit begins.

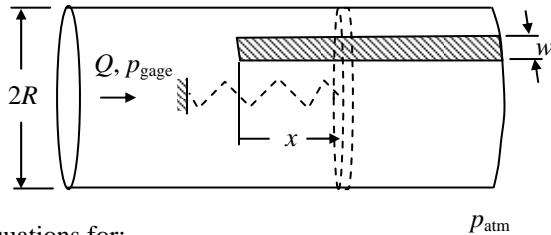

Derive equations for:

a. the volumetric flow rate, Q , and

b. the gage pressure in the tube, p_{gage} ,

in terms of (a subset of) the piston displacement, x , as well as the tube radius, R , slit width, w , spring constant, k , and the properties of air. Assume that the slit width, w , is so small that the outflow area is much smaller than the tube's cross-sectional area, πR^2 , even at the piston's full extension.

Answer(s):

$$p_{\text{gage}} = \frac{kx}{\pi R^2}$$

$$Q = wx^{3/2} \sqrt{\frac{2k}{\rho \pi R^2}}$$

Practice Problems on Bernoulli's Equation

bernoulli_13

Water 1 m deep is flowing steadily at 10 m/s in a channel 4 m wide. The channel drops 3 m at 30 deg, and simultaneously narrows to 2.5 m as shown in the accompanying sketch.

Determine the two possible water depths at downstream station B. Neglect all losses.

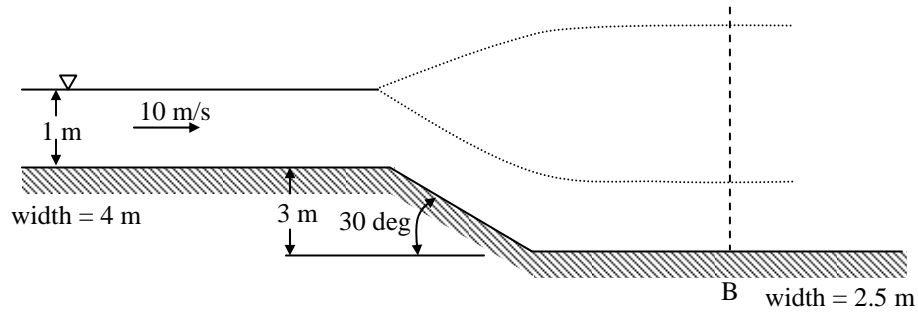

Answer(s):

1.7 m and 5.7 m

Practice Problems on Bernoulli's Equation

COLM_BE_01

A water tank with cross-sectional area, A_{tank} , is filled to height, h , and stands on a frictionless cart. A jet with area, A_{jet} , at height, h_{exit} , leaves the tank and is deflected by a vane at an angle, θ , from the horizontal. Compute the tension, T , in the supporting cable in terms of A_{tank} , A_{jet} , h , h_{exit} , g , and θ . Assume that $A_{\text{tank}} \gg A_{\text{jet}}$. Also assume that the velocity and area of the jet remain constant after leaving the tank.

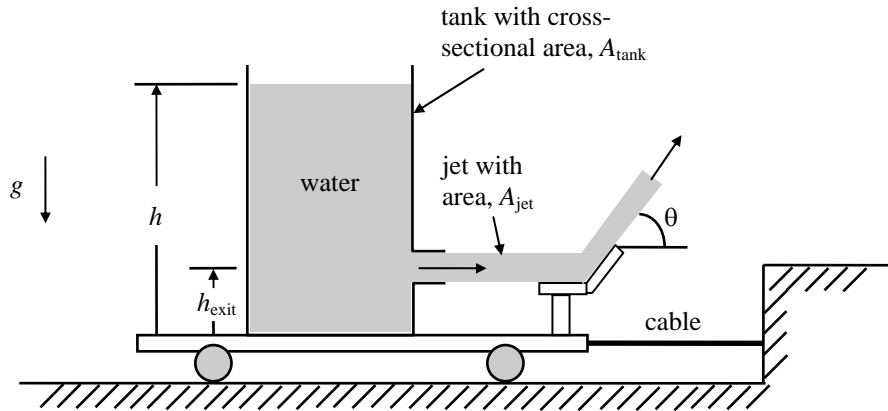

Answer(s):

$$\therefore T = 2\rho g (h - h_{\text{exit}}) \cos \theta A_{\text{jet}}$$

Practice Problems on Bernoulli's Equation

COLM_BE_03

An axi-symmetric body (e.g., a sphere) is mounted in a water tunnel which has a circular cross-section of radius R . The velocity far upstream is U_∞ . When the pressure far upstream, p_∞ , is lowered sufficiently, a large vapor-filled wake or cavity forms behind the body.

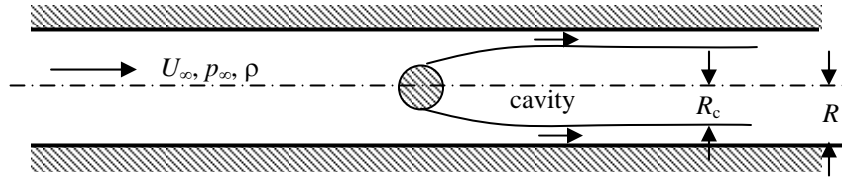

The pressure in the cavity is the vapor pressure, p_v , of the water ($p_v < p_\infty$). You may reasonably assume that the effects of friction and the amount of water vaporized at the free surface can be neglected and that the vapor density is much smaller than the water density.

A useful dimensionless parameter appearing when dealing with cavitation (the process of lowering the pressure below vapor pressure) is the cavitation number, σ , is defined as:

$$\sigma \equiv \frac{p_\infty - p_v}{\frac{1}{2} \rho U_\infty^2}$$

where ρ is the water density.

- Find the relation between the ratio R_c/R and σ for very long cavities whose asymptotic radius is R_c .
- Determine the drag acting on the body in terms of U_∞ , R , ρ , and σ .

Answer(s):

$$\left(\frac{R_c}{R}\right)^2 = 1 - \sqrt{\frac{1}{\sigma+1}}$$

$$\frac{D}{\frac{1}{2} \rho U_\infty^2 \pi R^2} = 2 - 2\sqrt{\sigma+1} + \sigma$$

Practice Problems on Bernoulli's Equation

COLM_BE_09

The axi-symmetric object shown below is placed in the end of a vertical circular pipe of inner diameter, D . A liquid with density, ρ , is pumped upward through the pipe and discharges to the atmosphere. Neglecting viscous effects, determine the volume flow rate, Q , of the liquid needed to support the object in the position shown in terms of d , D , g , ρ , and M .

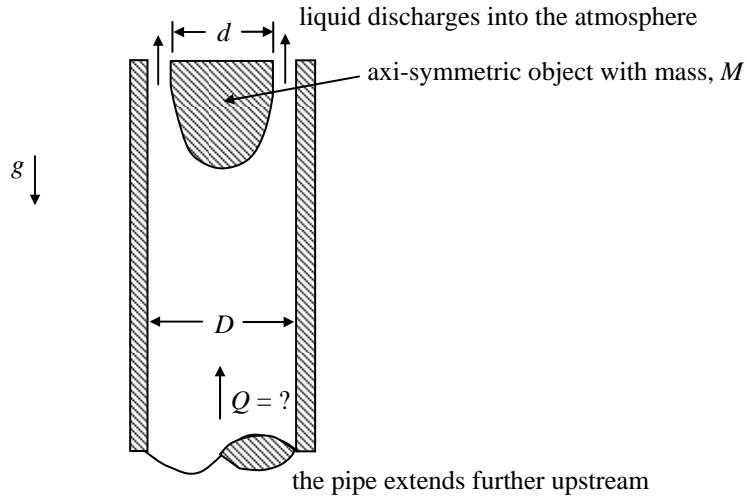

Answer(s):

$$\therefore Q = \sqrt{\frac{Mg}{\rho \frac{(A_{\text{in}} - A_{\text{out}})^2}{2A_{\text{in}}A_{\text{out}}}}} = \frac{1}{\left(\frac{A_{\text{in}}}{A_{\text{out}}} - 1\right)} \sqrt{\frac{2MgA_{\text{in}}}{\rho}} \quad \text{where } A_{\text{in}} = \frac{\pi D^2}{4} \quad \text{and} \quad A_{\text{out}} = \frac{\pi(D^2 - d^2)}{4}$$

Practice Problems on Bernoulli's Equation

COM_BE_02

A water tank has an orifice in the bottom of the tank:

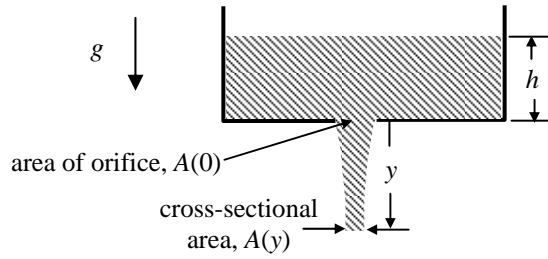

The height, h , of water in the tank is kept constant by a supply of water which is not shown. A jet of water emerges from the orifice; the cross-sectional area of the jet, $A(y)$, is a function of the vertical distance, y . Neglecting viscous effects and surface tension, find an expression for $A(y)$ in terms of $A(0)$, h , and y .

Answer(s):

$$\frac{A_2}{A_0} = \frac{1}{\sqrt{1 + \frac{y}{h}}}$$

Practice Problems on Bernoulli's Equation

COM_BE_03

In ancient Egypt, circular cross-sectioned vessels filled with water sometimes were used as crude clocks. The vessels were shaped in such a way that, as water drained from the bottom, the surface level dropped at a constant rate. Assuming that water drains from a small hole of area, A , find an expression for the radius of the vessel, r , as a function of the water level, h . Determine the volume of water needed so that the clock will operate for n hours.

Answer(s):

$$r_h = \left(\frac{A_E \sqrt{2g}}{\pi V_{FS}} \right)^{1/2} h^{1/4}$$
$$\therefore \text{Vol} = \frac{2}{3} A_E \sqrt{2g} n^{3/2} V_{FS}^{1/2}$$

Practice Problems on Bernoulli's Equation

unsteady_bernoulli_02

Consider a pipe of length L with variable cross-sectional area connected to a pump as shown in the figure. The cross-sectional area of the pipe varies linearly with position, x , from an initial area of A_1 to a final area of A_2 . Assume that just downstream of the pump the pressure remains constant at p_1 (absolute) and that the flow from the pipe discharges into the atmosphere with pressure p_{atm} (absolute). The pipe is horizontal so that the inlet and exit of the pipe are at the same elevation. At $t = 0$, where t is time, the fluid in the pipe is at rest. Assuming that the flow within the pipe is one-dimensional, incompressible, inviscid, and unsteady, derive an expression for the fluid velocity at the exit of the pipe (station 2) as a function of time.

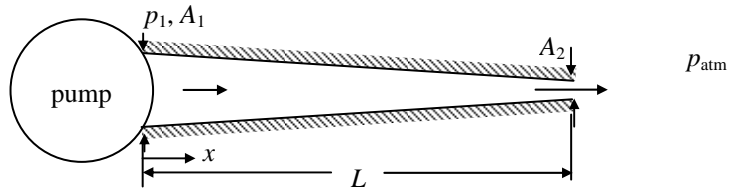

Answer(s):

$$\therefore V_2 = \left(\frac{\alpha}{\beta} \right) \left[\frac{1 + \exp(-2\alpha\beta t)}{1 - \exp(-2\alpha\beta t)} \right]$$