

Physics 203 Spring 2018

Final Exam

6/11/2018

Collaboration is not allowed. Allowed on your desk are: up to ten 8.5 x 11 inch doubled sided sheets of notes that are bound together, non-communicating scientific calculator, 1 page of scratch paper, writing utensils, and the exam. You will have 110 minutes to complete this exam.

Constants:

$$v_{\text{sound}} = 343 \text{ m/s (in air)}, \quad c = 3.0 \times 10^8 \text{ m/s}$$

$$k = 8.99 \times 10^9 \frac{\text{Nm}^2}{\text{C}^2}, \quad \epsilon_0 = 8.85 \times 10^{-12} \frac{\text{F}}{\text{m}}, \quad \mu_0 = 4\pi \times 10^{-7} \frac{\text{H}}{\text{m}}$$

1. (2 points each) For each figure, rank the electric potentials of each indicated point (sides of the bar in the bottom right figure) from least to greatest. (For example, $A < B = C < D$)

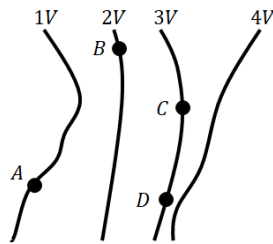

Ranking:

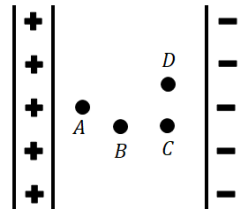

Ranking:

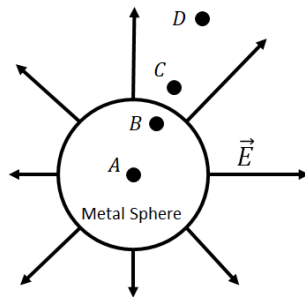

Ranking:

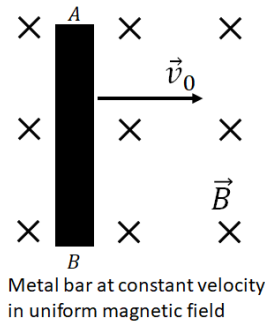

Ranking:

For questions 2 through 5 **fill in the square** next to all correct answers, a given problem may have more or less than one correct answer. Each correctly chosen answer will receive two points. There are 8 correct answers in this section and only the first 8 filled in answers will be graded. There is no partial credit.

2. Which of the following situations will produce a magnetic field pointed out of the page?

- a)
- b)
- c)
- d)
- e)
- f)
- g)

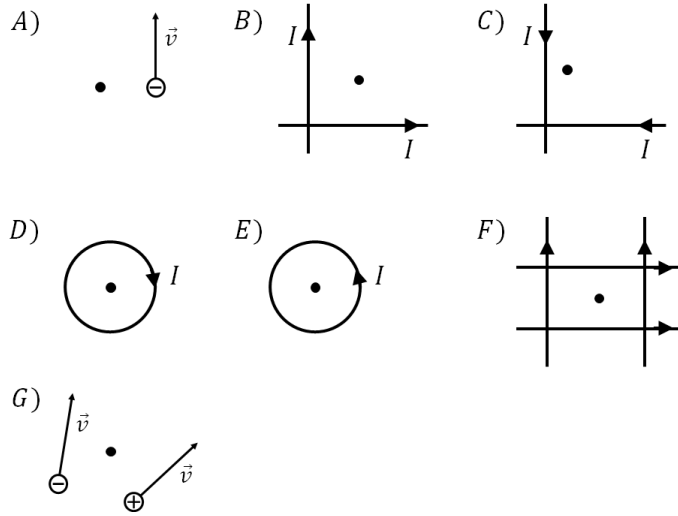

3. Which of the following circuits will cause the $2\ \Omega$ resistor to dissipate 8 W.

- a)
- b)
- c)
- d)
- e)
- f)

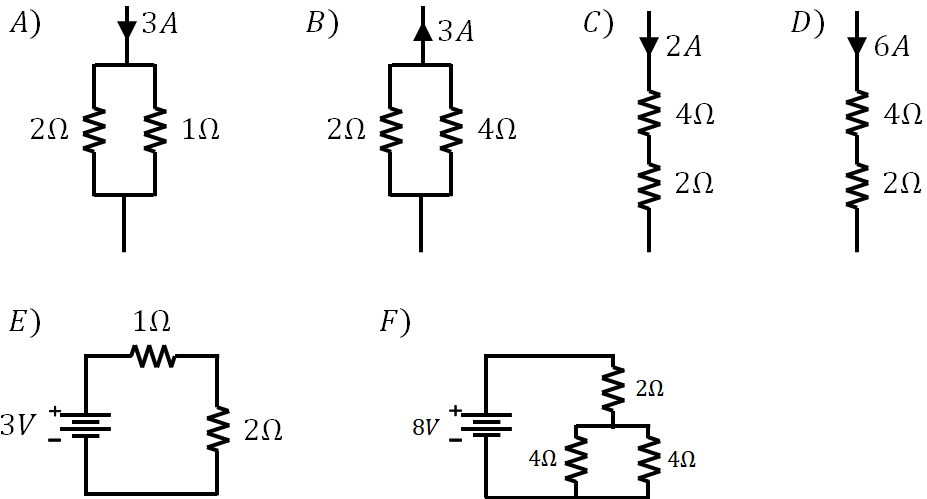

4. Two speakers are set on the ground, the second speaker is set a distance D meters directly to the right of the first speaker. Both speakers point to the right. A sound wave with a frequency of 114.3 Hz is emitted from each. The sound waves from the speakers are emitted 180° out of phase with each other. What distance(s), D , will result in destructive interference well to the right of both speakers?

- a) 0 *m*
- b) 1.0 *m*
- c) 1.5 *m*
- d) 2.0 *m*
- e) 3.0 *m*
- f) 4.5 *m*

5. Which of the following thicknesses of an olive oil film ($n = 1.46$) sitting on top of water ($n = 1.33$) will result in constructive interference for yellow light ($\lambda = 578 \text{ nm}$) incident from the air above the oil?

- a) 578 *nm*
- b) 396 *nm*
- c) 297 *nm*
- d) 289 *nm*
- e) 198 *nm*
- f) 145 *nm*
- g) 99 *nm*

6. (3 points) The following circuit has the specified voltages, currents, and resistances. Use Kirchhoff's loop rule to write an equation that describes the loop indicated by the bold circle and darker wires.

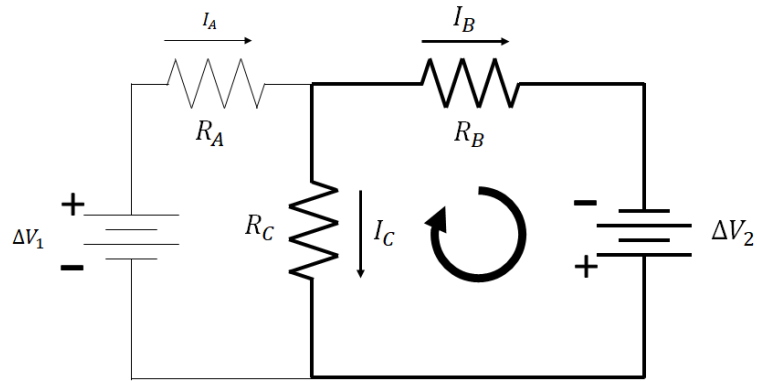

7. (4 points) Four resistors are made of the same material. Rank the resistors A, B, C, and D from least to greatest resistance.

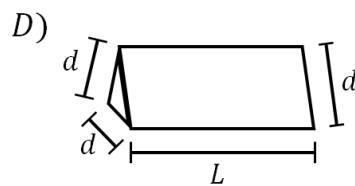
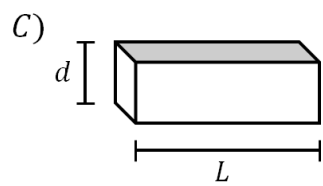
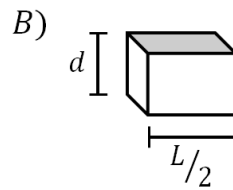
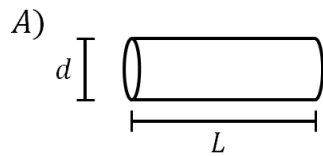

Ranking:

8. (6 points) A very long wire is bent into the following shape. The circular portion has a radius R and the whole wire carries a current I .

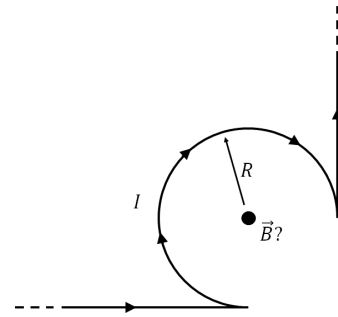

What are the magnitude and direction of the magnetic field at the black dot in the center of the arc?

9. (4 points) Rank the identical lightbulbs from brightest to dimmest. (Show your work or reasoning for partial credit!!!)

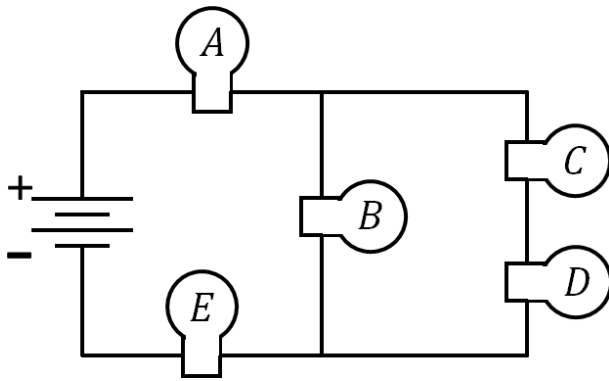

Ranking:

10. (7 points) At $t = 0$, a particle with a charge of -4.0 C and mass $1.5\ \mu\text{g}$ is moving in the $+x$ direction with velocity 0.9 m/s through a magnetic field of $1.0\ \mu\text{T}$ pointed in the $-z$ direction.

a) (2 points) What direction is the force on the particle?

b) (1 point) What is the radius of the circle in which the particle travels?

c) (2 points) How long does it take the particle to make one full circle?

d) (2 points) If we average over a large period of time, we could say the particle travelling in a circle was a circular current. What is the magnitude of this current? (If you did not get part c, state this clearly, then solve for the current assuming it takes 2 seconds to make one full circle)

11. (8 points) Two negative particles are travelling in the $+y$ direction with identical velocities and y coordinates. Particle 1 is a distance $\frac{d}{2}$ in the $-x$ direction from the y axis, particle 2 is a distance $\frac{d}{2}$ in the $+x$ direction from the y axis.

a) (2 points) In what direction is the electric force on particle 1? Explain.

b) (4 points) In what direction is the magnetic force on particle 1? **Explain.**

c) (2 points) If the particles are in (dynamic) equilibrium, how fast must they be travelling? (Ignoring relativity, you should be able to give a numerical answer! Notice anything interesting about the value of the speed?)

12. (8 points) Below is a schematic of a dynamic microphone. Explain how the mic creates an electrical signal from a voice.

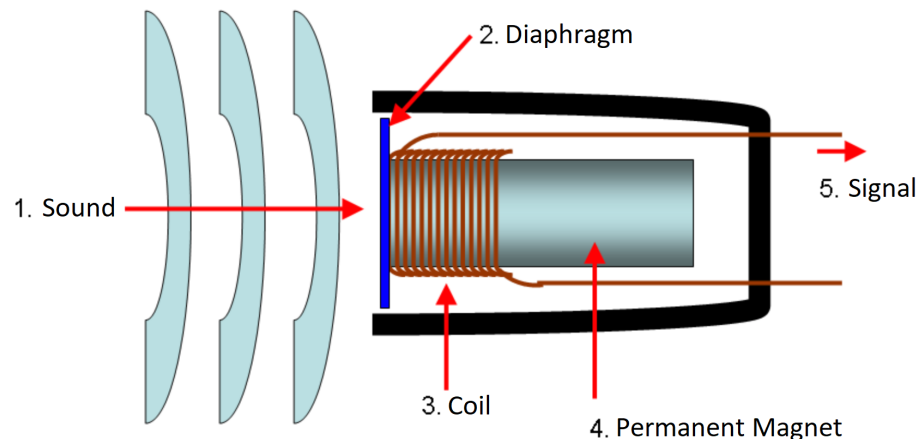

13. (8 points) A toy dinosaur is 10 cm to the left of an optical element (lens or mirror). The image of the dinosaur appears 20 cm to the right of the optical element. Both the toy dinosaur and its image appear right side up.

a) (6 points) What type(s) of optical element(s) (Converging Lens, Diverging Lens, Concave Mirror, Convex Mirror, or Plane Mirror) could create such an image? Find the focal length of the optical element(s). Explain (briefly!) your reasoning for full credit.

b) (2 points) For the possible optical element(s) you found, is the image a real or virtual image? How do you know? (if you found more than one element, give the image type for each)