



WE WERE GOING TO USE THE TIME MACHINE TO PREVENT THE ROBOT APOCALYPSE, BUT THE GUY WHO BUILT IT WAS AN ELECTRICAL ENGINEER.

www.xkcd.com

Circuits Module

- Micro. model
 - Resistivity vs. resistance
 - Ohm's law
 - Power!!!
 - Kirchhoff's Loop + Junction Rules
 - Equivalent Circuits
- } Wed
- } Fri
- } Mon
- } Wed

Microscopic Model of

Charge flow (current)

What happens?

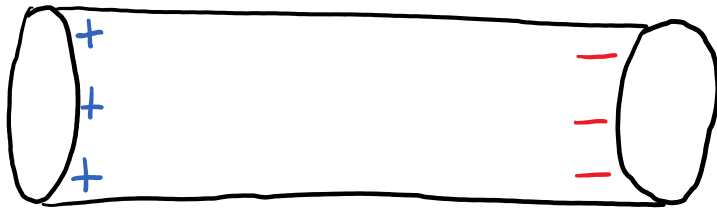
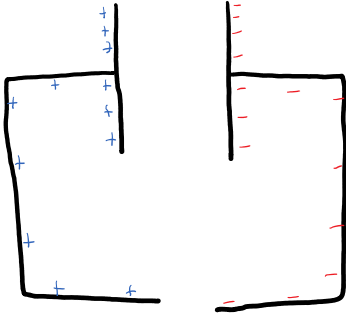

- Charge gradient
- Electric field
- Electric Potential hill

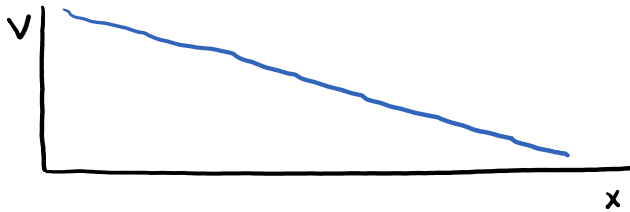

W/o Electric field



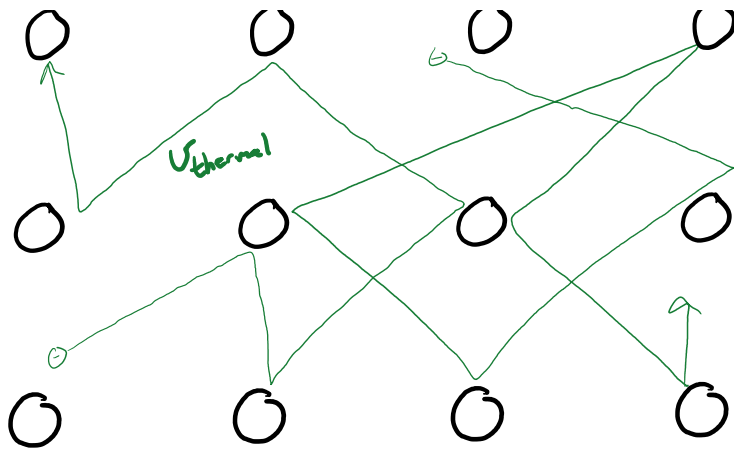

With Electric Field

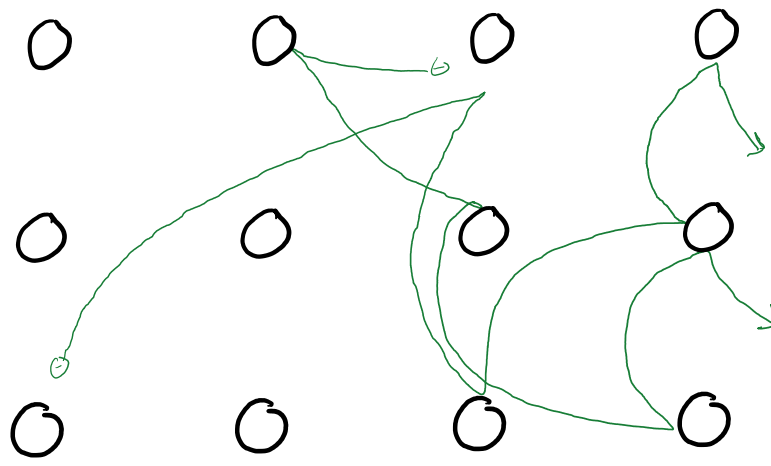

$\vec{v}_{drift} \rightarrow$

What happens when you turn on a light switch?
 (how long does it take light to)

(how long does it take light to
turn on?)

U_{drift} for copper @ 0.1 Amp ($\frac{C}{s}$)
is 10^{-5} m/s!

how far do electrons travel
in 1 hour?

Ohm's Law

$$\Delta V = I R$$

Def'n of Current

$$I = \frac{\Delta q}{\Delta t}$$

Resistivity

$$\rho = \frac{1}{\sigma}$$

Resistance

$$R = \rho \frac{L}{A}$$

Charges are not able to move completely freely through a wire, e.g., there is some resistance to their motion. If charges are flowing through a conducting wire, which one of the following statements are true?

1. The electric field inside a conductor is zero.
2. The electric potential difference between the ends of the wire is zero.
3. The electric field is non-zero inside the wire.
4. The electric potential difference between the ends of the wire is not zero.

You're attempting to make a resistive wire for melting ice off windows that will be connected to a constant voltage source. Which of the following quantities are independent of the length and radius of the wire you use?

1. conductivity
2. conductance
3. free electron density
4. resistivity
5. resistance
6. current through the wire
7. voltage difference across the wire

If you need to increase the radius of a resistive wire by a factor of 2, but keep the resistance the same, by what factor does the length need to change?

1. $1/4$
2. $1/2$
3. $2/3$
4. $3/2$
5. 2
6. 4
7. 16

Each of the following resistors is made of the same material (with resistance ρ)

Rank the resistances, R , of the resistors from least to greatest

Hint: $R = \frac{\rho L}{A}$

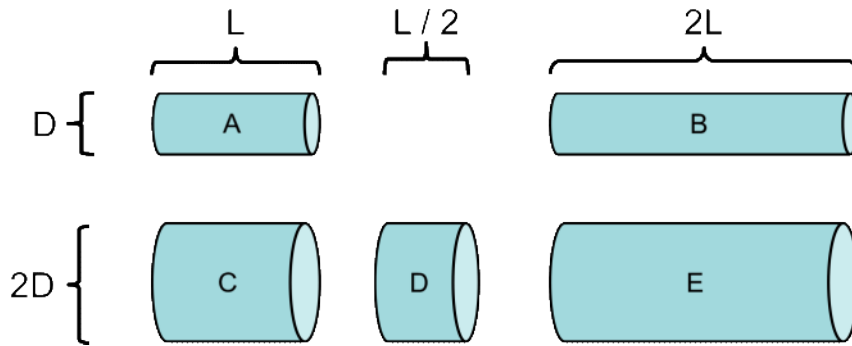

An electric car accelerates for 8.0 s by drawing energy from its 320-V battery pack. During this time the current through the battery is 163 A. How many Coulombs of charge were transferred through the battery?

1. 40 C
2. 800 C
3. 1300 C
4. 14,400 C
5. 25,600 C

If the 320 V are multiplied by the Coulombs of charge transferred through the battery during this time, what type of quantity would result?

1. force
2. electric potential
3. energy
4. electric field
5. current
6. resistance
7. work

A few really cool caveats!

Superconductivity!

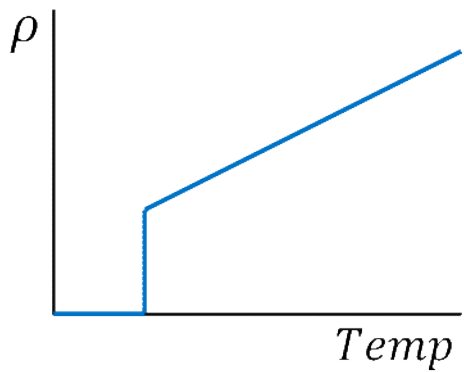

Non-"Ohmic" materials

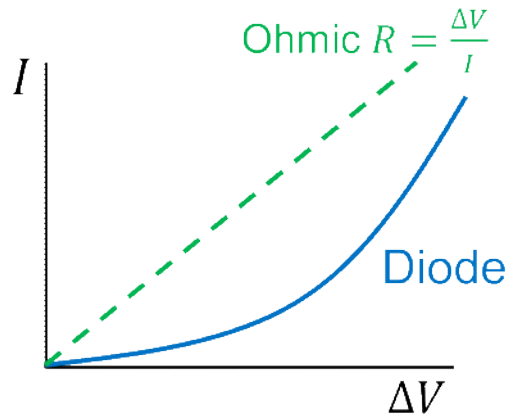

Circuits Module

Micro. model
Resistivity vs. resistance } Wed
Ohm's law } Fri

Ohm's law }
 iii Power!!! } Fri
 Kirchhoff's Loop + Junction Rules } Mon
 Equivalent Circuits } Wed

Tools you will need:

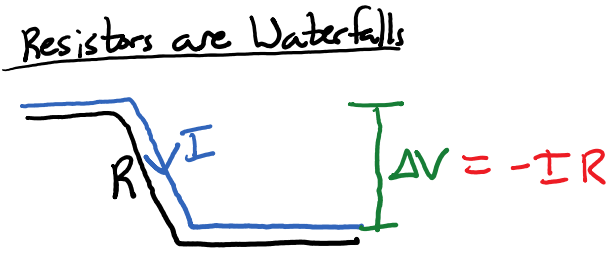
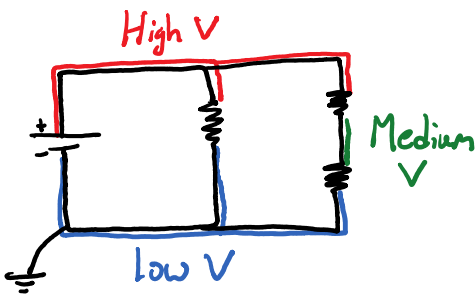

$$I = \frac{\Delta q}{\Delta t}$$

$$\Delta V = IR$$

$$P = I\Delta V$$

$$= I^2 R$$

$$= \Delta V^2 / R$$

Junction Rule

$$\sum I_{in} = \sum I_{out}$$

Loop Rule

$$\sum \Delta V_{loop} = 0$$

In the 3D diagram below, sketch the potential around the circuit shown above when the switch is closed.

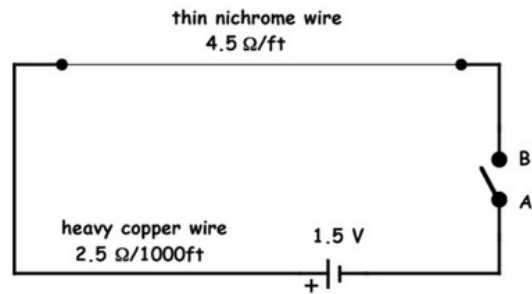
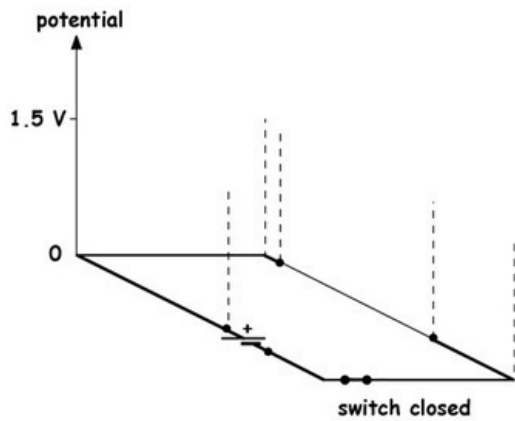

A constant potential difference V is applied across two resistors connected in series as shown. The current through the $2\ \Omega$ resistor is 2 A . What is the current through the $4\ \Omega$ resistor?

1. 0 A
2. 1 A
3. 2 A
4. 4 A
5. Need to know the potential difference

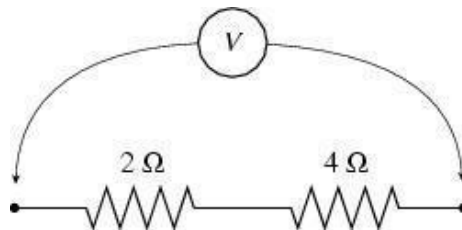

b) What is the voltage drop across each resistor?

c) What is the power dissipated by the $2\ \Omega$ resistor?

Consider the Y-shaped tube shown below. Suppose 2 balls per second are stuffed into the opening at A. The number of balls per second that come out of the tube at B is

1. always equal to 2
2. always smaller than or equal to 2
3. always larger than or equal to 2
4. equal to 1
5. depends on what happens at C

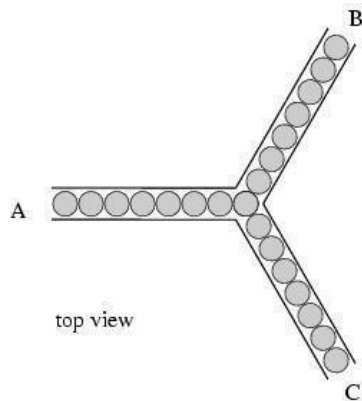

A light bulb is connected to a 9-V battery. If a second battery is added in a series as shown in (b), how many of the following change?

- The current I at A
- The potential difference V_{AB} between A and B
- The resistance R of the light bulb

1. All three
2. Two
3. One
4. It depends

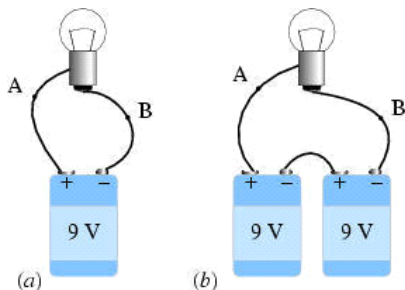

Consider the following circuit with three light bulbs of equal resistance. Rank the relative brightness of each bulb?

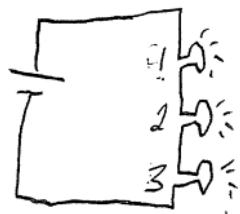

If $R_1 < R_2 = R_3$, What will be the relative brightness of each bulb?

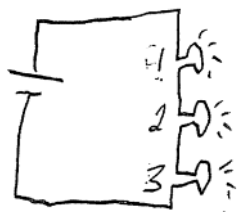

Consider the following circuit with three light bulbs. Which equation would be most useful for determining the relative brightness of each bulb if the relative resistances are known?

1. $\Delta V = IR$
2. $P = \Delta V^2/R$
3. $P = I\Delta V$
4. $P = I^2R$

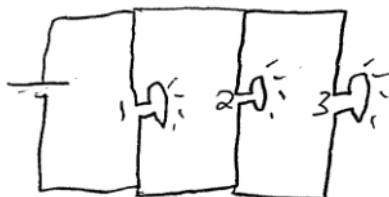

Consider the two circuits with three identical light bulbs and an identical voltage source. Which circuit will have brighter bulbs?

1. Series
2. Parallel
3. Equal

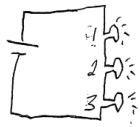
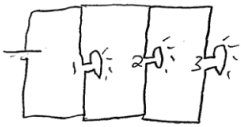

Consider the following circuit with five equal resistance light bulbs. What is the relative brightness of each bulb?

1. $1 > 2 = 3 > 4 = 5$
2. $1 < 2 = 3 < 4 = 5$
3. $1 > 2 = 3 = 4 = 5$
4. $1 > 4 = 5 > 2 = 3$
5. $1 < 4 = 5 < 2 = 3$

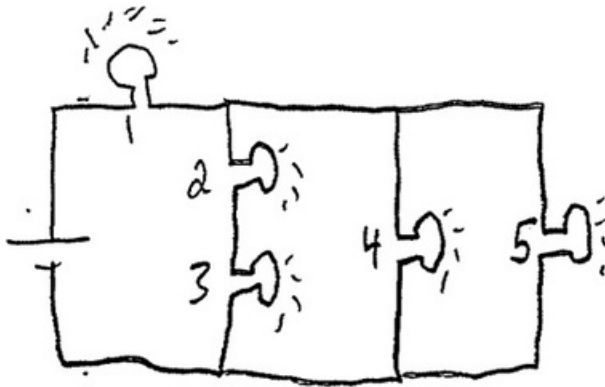

Bonus question!

3.5 A of current is flowing through a 4.2 Ohm resistor. Find:

- a) The voltage drop across the resistor.

b) The power dissipated by the resistor.

c) How much potential energy the electrons are losing by traveling through the resistor.

Circuits Module

Micro. model

Resistivity vs. resistance } Wed

Ohm's law } Fri

iii Power!!!

Kirchhoff's Loop + Junction Rules } Mon

Equivalent Circuits } Wed

Method 1: (Always works!)

Kirchhoff's Loop and Junction Rules

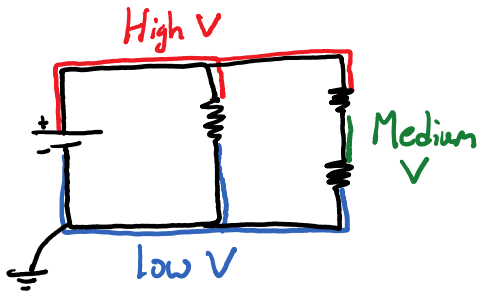

Resistors are Waterfalls

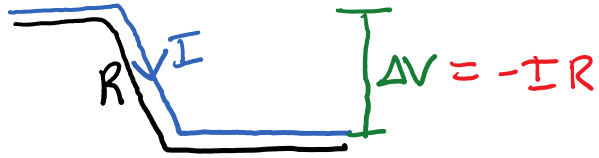

Loop Rule

$$\sum \Delta V_{loop} = 0$$

Junction Rule

$$\sum I_{in} = \sum I_{out}$$

What is the electrical potential at point A in the circuit?

1. +9V
2. -9V
3. +6V
4. +3V
5. 0V
6. Can't determine with the information given.

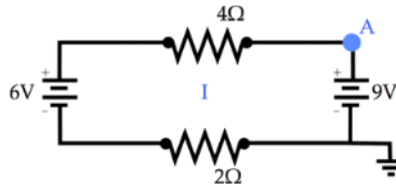

Consider the following circuit. List the four potential voltage drops (and gains) ΔV encountered going around the loop (don't include units). Express your answer as a sum that should be zero according to Krichhoff's voltage rule: i.e. " $1 + 1i + -12i + -2i$ "

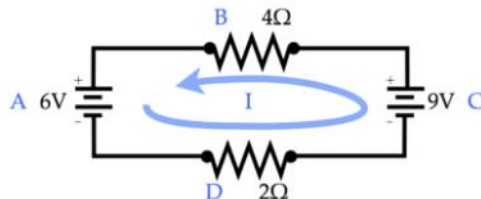

Consider the circuit in the figure below where I_1 is the current that goes through R_1 , I_2 goes through R_2 , and I_3 goes through R_3 . What is the voltage drop across resistor R_1 ?

1. $\Delta V_1 = I_1 R_1$
2. $\Delta V_1 = -I_1 R_1$
3. $\Delta V_1 = -I_{\text{total}} R_1$

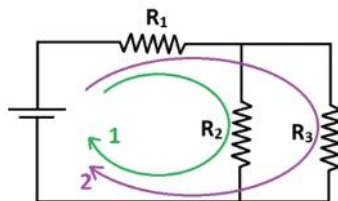

Which equation satisfies Kirchhoff's loop rule when following loop 1?

1. $+\epsilon + I_1 R_1 + I_2 R_2 = 0$
2. $+\epsilon - I_1 R_1 - I_2 R_2 = 0$
3. $+\epsilon - I_1 R_1 - I_2 R_2 = 0$
4. $+\epsilon + I_1 R_1 + I_2 R_2 = 0$

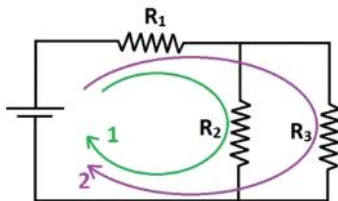

Which equation satisfies Kirchhoff's loop rule when following loop 2?

1. $+\epsilon + I_1 R_1 + I_3 R_3 = 0$
2. $+\epsilon - I_1 R_1 - I_3 R_3 = 0$
3. $+\epsilon - I_1 R_1 - I_2 R_2 - I_3 R_3 = 0$
4. $+\epsilon + I_1 R_1 + I_3 R_3 = 0$

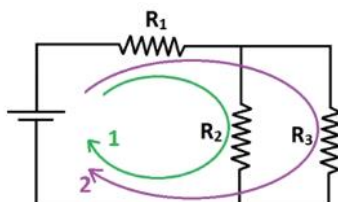

Which equation satisfies Kirchhoff's junction rule?

1. $I_1 + I_3 = I_2$
2. $I_1 - I_2 = I_3$
3. $I_1 + I_2 = I_3$
4. $I_2 + I_3 = I_1$
5. $V_1 + V_3 = V_2$
6. $V_1 + V_2 = V_3$

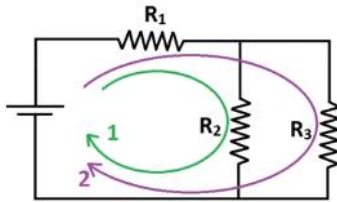

With the following values, solve for the current in each segment of the circuit:

$\epsilon = 11 \text{ V}$
 $R_1 = 2 \ \Omega$
 $R_2 = 4 \ \Omega$
 $R_3 = 6 \ \Omega$

1. $I_1 = 2.5 \text{ A}, I_2 = 1.5 \text{ A}, I_3 = 1 \text{ A}$
2. $I_1 = 1 \text{ A}, I_2 = 1.5 \text{ A}, I_3 = 2.5 \text{ A}$
3. $I_1 = 2.5 \text{ A}, I_2 = -1.5 \text{ A}, I_3 = 1 \text{ A}$
4. $I_1 = 2.5 \text{ A}, I_2 = 1.5 \text{ A}, I_3 = -1 \text{ A}$

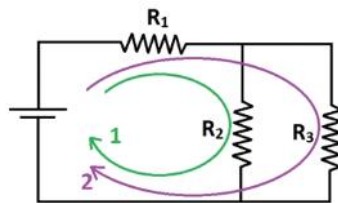

Let I_1 be the current through R_1 , I_2 be the current through R_2 , and I_3 be the current through R_3 . Rank the current that goes through each resistor from least to greatest.

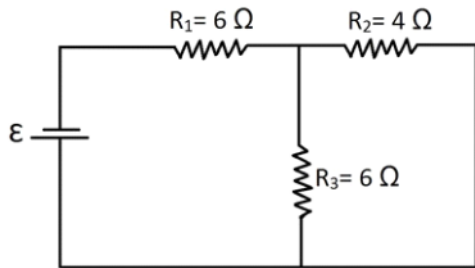

Challenge Problem!

Consider the circuit below. What minimum number of loops can be used when applying Kirchhoff's loop rule to completely account for each element?

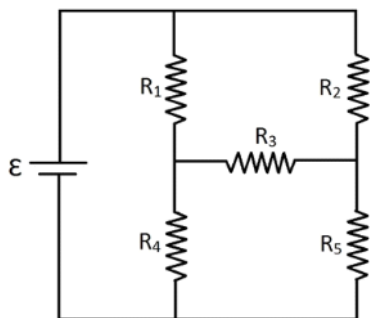

Let I_1 be the current through R_1 , I_2 be the current through R_2 ... How many values of I are present in this circuit?

How many *unique* current junctions are there?

How many *unique* current junctions are there?

Which set of equations is valid for this circuit?

a)

$$\begin{aligned} +\epsilon - I_1 R_1 - I_4 R_4 &= 0 \\ +\epsilon - I_2 R_2 - I_5 R_5 &= 0 \\ -I_2 R_2 + I_3 R_3 + I_1 R_1 &= 0 \\ -I_5 R_5 + I_4 R_4 - I_3 R_3 &= 0 \end{aligned}$$

b)

$$\begin{aligned} +\epsilon - I_1 R_1 - I_4 R_4 &= 0 \\ +\epsilon - I_2 R_2 - I_5 R_5 &= 0 \\ +\epsilon - I_2 R_2 + I_3 R_3 + I_1 R_1 &= 0 \\ +\epsilon - I_5 R_5 + I_4 R_4 - I_3 R_3 &= 0 \end{aligned}$$

c)

$$\begin{aligned} -I_1 R_1 - I_4 R_4 &= 0 \\ -I_2 R_2 - I_5 R_5 &= 0 \\ -I_2 R_2 + I_3 R_3 + I_1 R_1 &= 0 \\ -I_5 R_5 + I_4 R_4 - I_3 R_3 &= 0 \end{aligned}$$

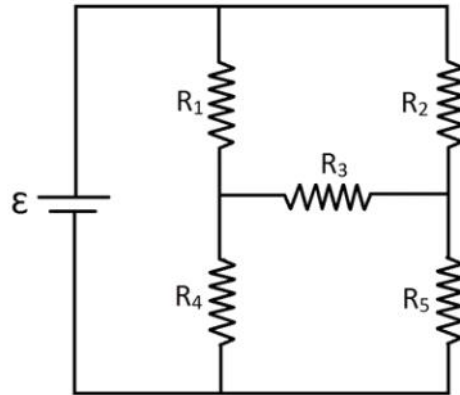

**Another challenge problem! (this one is easier!)
(assume each resistor is 1Ω , and the battery is 1 V)**

Find the current through the red resistor!

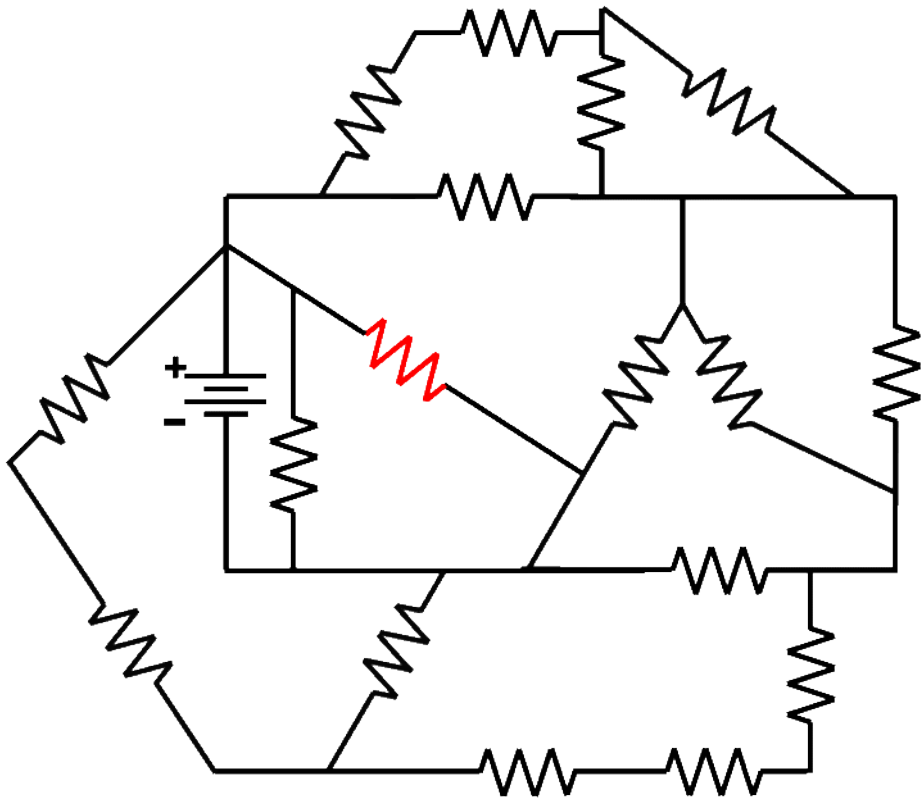

Circuits Module

Micro. model
Resistivity vs. resistance } Wed
Ohm's law } Fri
iiiPower!!! }

iii Power!!! } Fri
 Kirchhoff's Loop + Junction Rules } Mon
 Equivalent Circuits } Wed

Method 2: (Sometimes works!)

Equivalent Circuits

Series

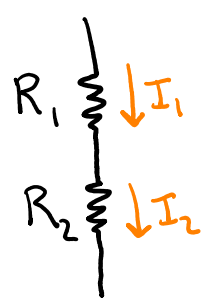

Equivalent Circuit

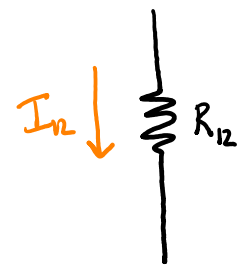

Equivalent Resistance

$$R_{12} = R_1 + R_2$$

$$I_1 = I_2 = I_{12}$$

Parallel

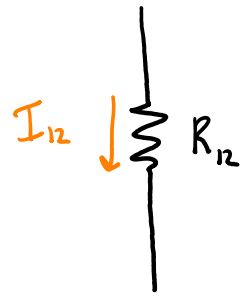
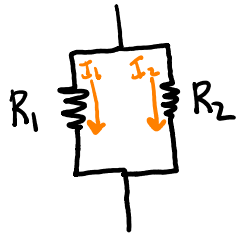

$$\frac{1}{R_{12}} = \frac{1}{R_1} + \frac{1}{R_2}$$

$$I_1 + I_2 = I_{12}$$

a)

b)

c)

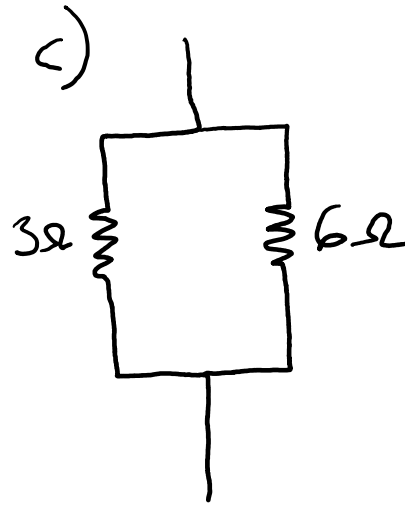
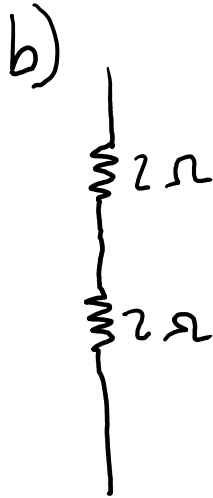
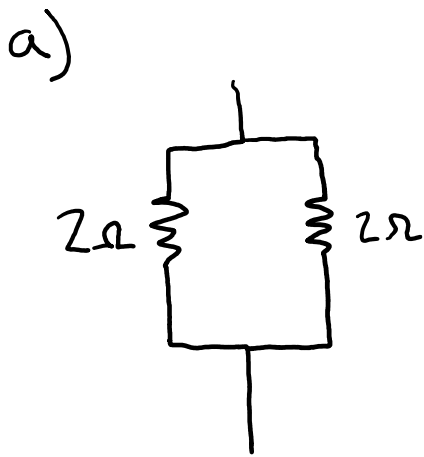

As more identical resistors, R , are added to the parallel circuit shown here, the total resistance between points P and Q

1. increases.
2. remains the same.
3. decreases.

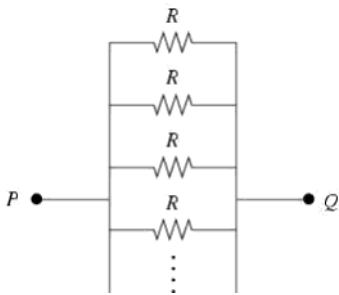

Draw a graph relating the total resistance R_{total} between points P and Q versus the total number N of resistors placed between them.

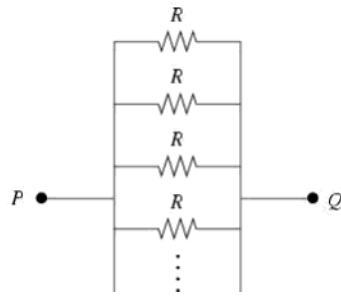
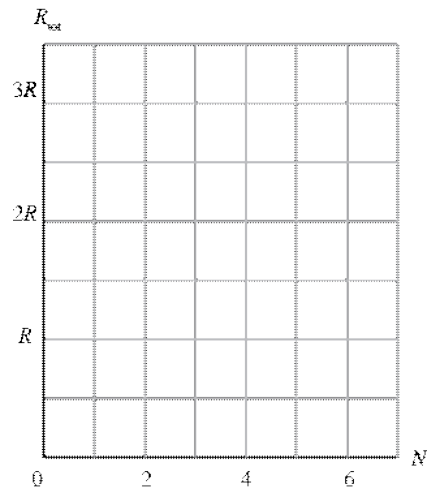

Draw a graph relating the total resistance as a function of N , where N is the number of equivalent 0.5Ω resistors added in series.

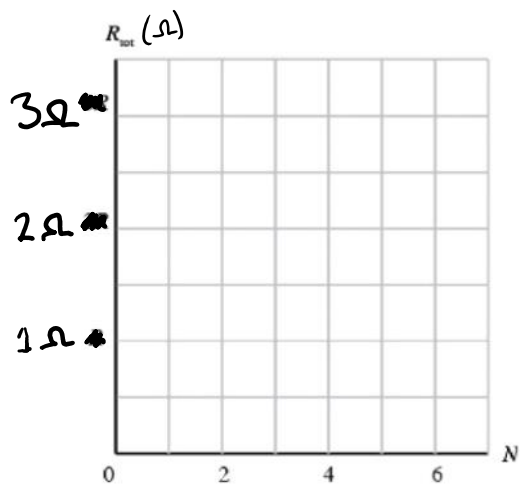

Charge flows through a light bulb. Suppose a wire is connected across the bulb as shown. When the wire is connected,

1. all the charge continues to flow through the bulb.
2. half the charge flows through the wire, the other half continues through the bulb.
3. all the charge flows through the wire.
4. none of the above.

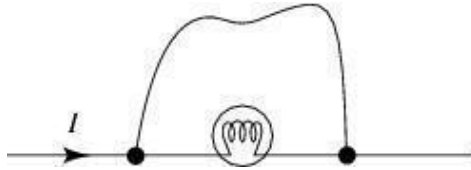

The circuit below consists of two identical light bulbs burning with equal brightness and a single 12 V battery. When the switch is closed, the brightness of bulb A

1. increases.
2. remains unchanged.
3. decreases.

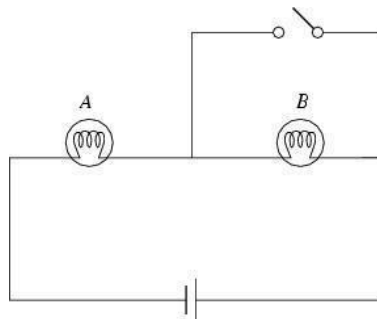

With the switch S closed, what is the equivalent resistance of the circuit?

1. $4R$
2. $2R/3$
3. $2R$
4. $5R/3$
5. $5R/6$
6. R
7. $R/3$
8. $R/2$

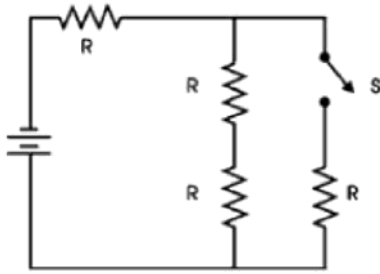

Consider the following circuit. Will more power be dissipated by the circuit when the switch S is open or closed?

1. open
2. closed
3. no difference

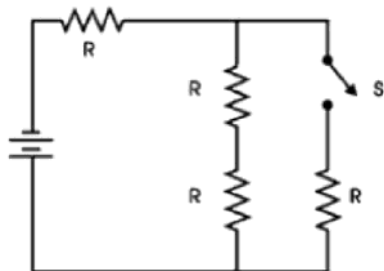

Use the voltage vs. current curve for the resistors to determine what power is delivered to the circuit by a 12 V battery when the switch is closed?

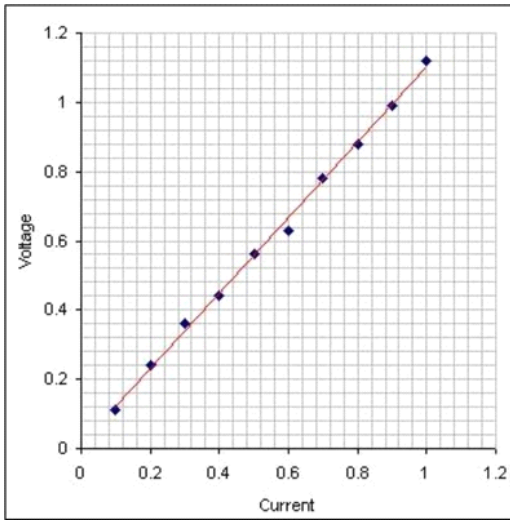

Find the equivalent resistance of the following circuit.

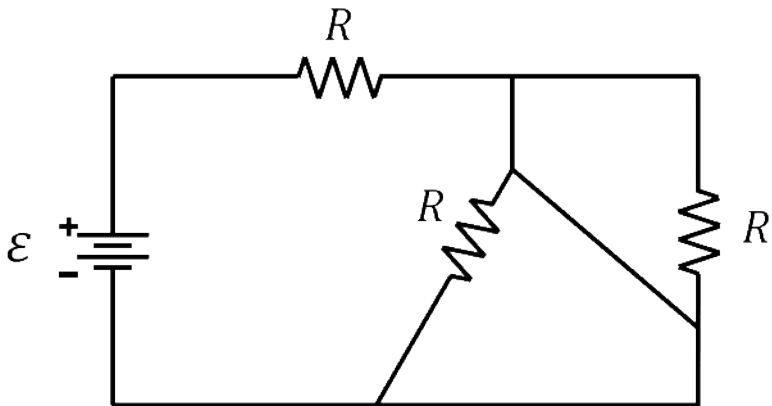

Try to find the currents in this circuit!

$$R_1 = 3\Omega$$

$$R_2 = R_3 = 4\Omega$$

$$\varepsilon = 5V$$

Find:

$$R_{eq}, I_{tot}$$

$$I_1, V_1, I_2, V_2$$

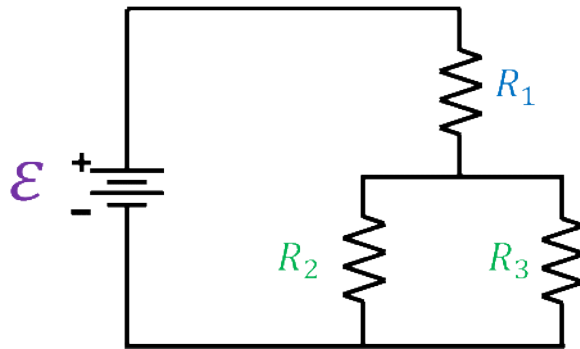

Find the equivalent resistance of this circuit

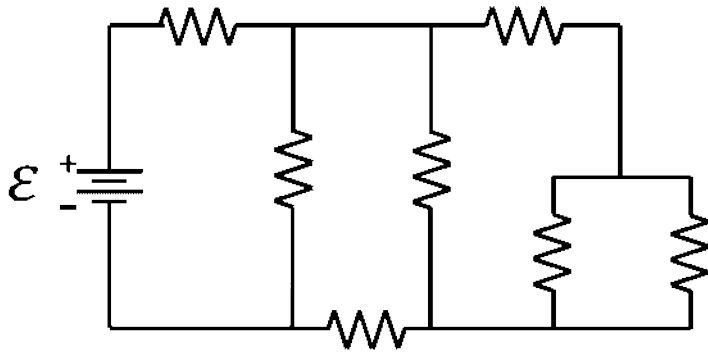

b) How much power would the bottom resistor dissipate if the battery's EMF was 9V?