

Fluid Mechanics

Foundation Stage (FS.2.L2)

Lecture 2 Hydraulics, Buoyancy

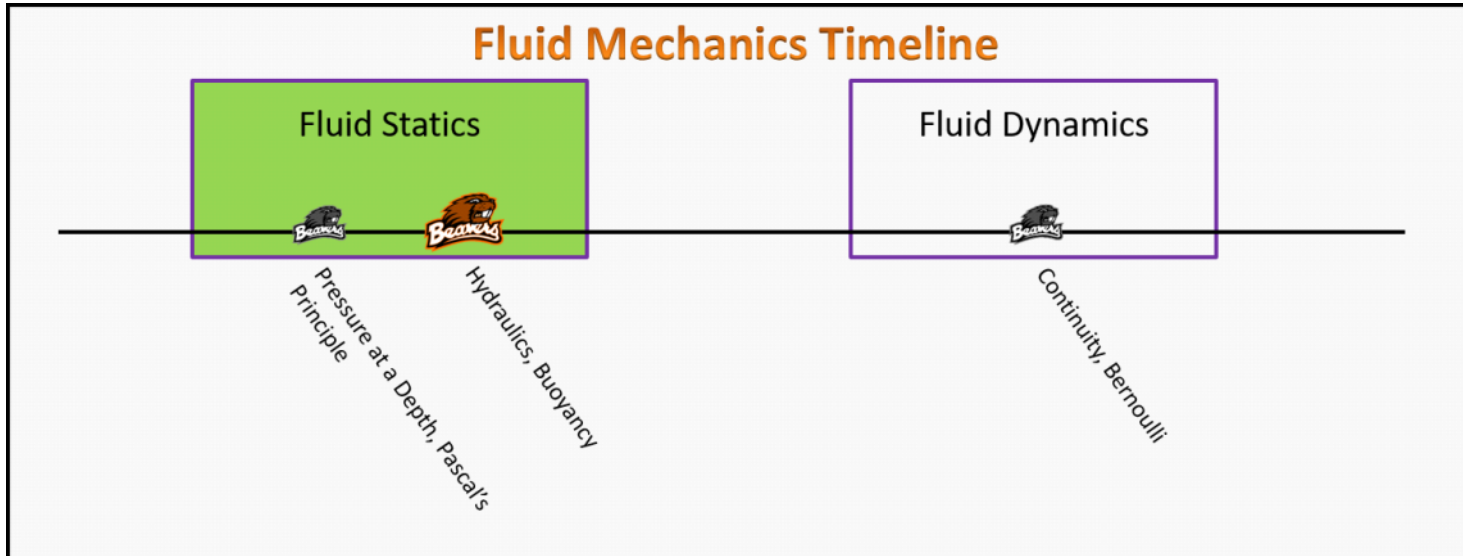

Textbook Chapters (* Calculus version)

- **BoxSand** :: KC videos ([Buoyancy](#))
- **Knight** (College Physics : A strategic approach 3rd) :: 13.4
- ***Knight** (Physics for Scientists and Engineers 4th) :: 14.4
- **Giancoli** (Physics Principles with Applications 7th) :: 10-7

Warm up

FS.2.L2-1:

Description: Describe what pressure means in terms of forces and areas.

Learning Objectives: [?] - Can you identify the objectives from the previous lecture, and this lecture, that this question is relevant to?

Problem Statement: A box of 1 m x 1 m x 1 m (L x W x H) is submerged 1 meter underwater as shown in the image below. The container of water the box is in is near the surface of the earth, so the pressure right outside the water is atmospheric pressure.

(a) Calculate the pressure at the top surface of the box.

(b) Calculate the pressure at the bottom surface of the box.

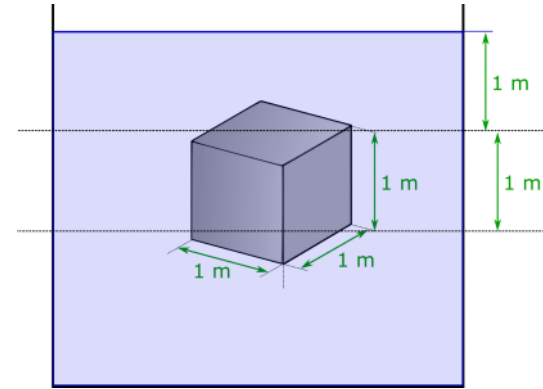

(c) Calculate the force from the pressure at the top of the box. (d) Calculate the force from the pressure at the bottom of the box.

(e) What is the sum of the two forces due to the pressures at the top and bottom of the box. Be careful with signs.

(f) Use the definition of buoyant force $|\vec{F}^B| = \rho_f V_{fd} g$ to calculate the value of the buoyant force and compare it to your answer from part (e). What can you conclude about the buoyant force definition?

Hints: ρ_f is the density of the fluid which is water in this problem, V_{fd} is the volume of the fluid that the object displaces which is just the volume of the object in the problem because the entire block is submerged, finally g is the acceleration of an object in free-fall.

Selected Learning Objectives

1. Coming soon to a lecture template near you.

Key Terms

- Archimedes Principle
- Buoyant force

Key Equations

$$|\vec{F}^B| = \rho_f V_{fd} g$$

Key Concepts

- Coming soon to a lecture template near you.

Questions

Act I: Hydraulics

FS.2.L2-2:

Description: Identify which PV diagram represents an isochoric process. (2 minutes + 2 minutes)

Learning Objectives: [1, 12, 13]

Problem Statement: Consider the odd shaped container shown below.

(a) You pour water into the left most tube only. Rank the heights of the fluid in each tube at equilibrium.

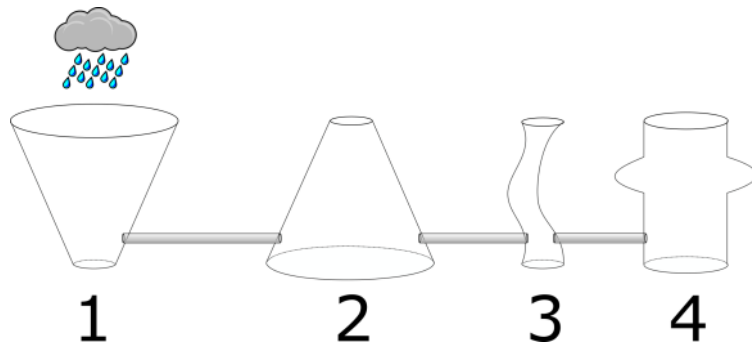

(b) Rank the pressure at the bottom of each tube.

FS.2.L2-3:

Description: Proportional reasoning with ideal gas law. (3 minutes)

Learning Objectives: [1, 12, 13]

Problem Statement: Consider two different masses are initially placed on top of equal area low friction pistons as shown in the figure below. The container has a third piston where a force F is applied such that it doesn't move.

(a) What happens to the other two pistons?

- (1) The 1000 kg and 600 kg masses move upwards.
- (2) The 1000 kg mass moves upwards while the 600 kg mass moves downwards.
- (3) The 1000 kg and 600 kg masses move downwards.
- (4) The 1000 kg mass moves downwards while the 600 kg mass remains still.
- (5) The 1000 kg mass moves downwards while the 600 kg mass moves upwards.
- (6) Both the 1000 kg and 600 kg mass remain at rest.

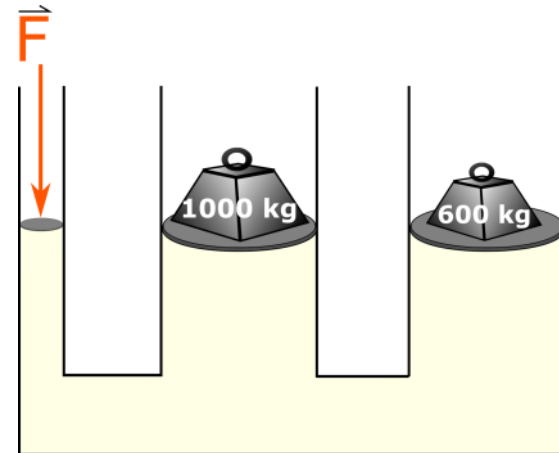

(b) Which of the following actions could cause the 1000 kg mass to move upwards and the 600 kg mass to move downwards.

- (1) Make the area under the 600 kg mass smaller.
- (2) Make the area under the 1000 kg mass smaller.
- (3) Make the area under the 600 kg mass larger.
- (4) Make the area under the 1000 kg mass larger.
- (5) No actions can cause the 1000 kg mass to move upwards and the 600 kg mass downwards.

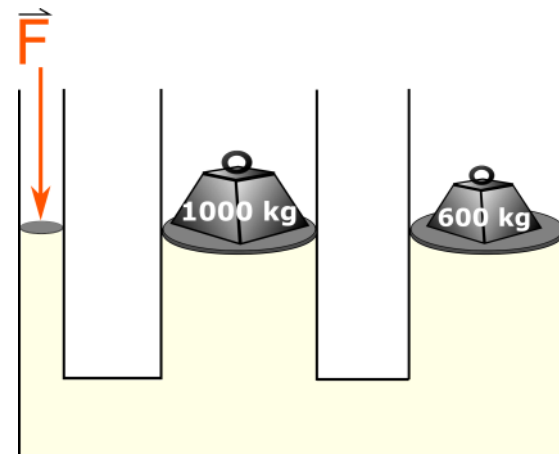

FS.2.L2-4:

Description: Determine signs of first law quantities. (5 minutes)

Learning Objectives: [1, 12, 13]

Problem Statement: We eventually wish to rank the forces required to balance the masses on frictionless pistons. The areas of all the pistons holding the masses are the same. The areas of the pistons where the forces are applied are also the same.

(a) Consider system 3, which of the following statements are true?

- (1) $P_L = P_M = P_R$
- (2) $P_L > P_M > P_R$
- (3) $P_L < P_M < P_R$
- (4) $P_L > P_M = P_R$
- (5) $P_L < P_M = P_R$

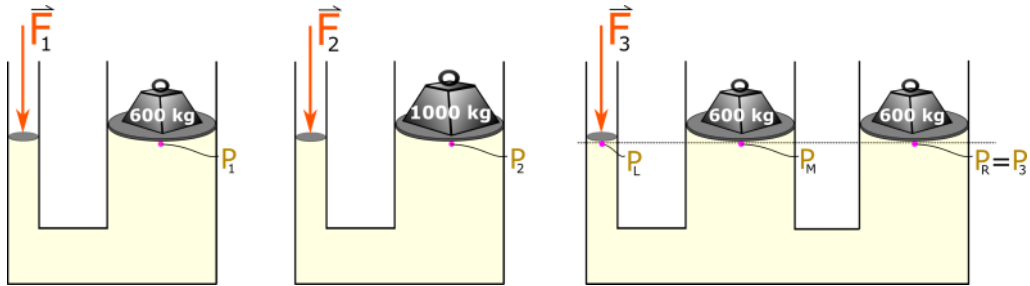

(b) Which of the following is true comparing P_1 and P_3 ?

- (1) $P_1 = P_3$
- (2) $P_1 > P_3$
- (3) $P_1 < P_3$
- (4) Unable to determine because they are separate containers.

(c) Rank the magnitude forces required to balance the masses at the same height as shown.

FS.2.L2-5:

Description: Identify which diagram represents an isothermal process. (2 minutes)

Learning Objectives: [1, 12, 13]

Problem Statement: Consider the image below which is a very basic hydraulic lift with a level that pushes down on a small frictionless piston, which in turn applies pressure on the oil which then lifts the object. Many hydraulic car jacks work in a similar way.

(a) What ratio of radii (r_3/r_2) would give you a hydraulic mechanical advantage of 3?



- (1) $1/9$
- (2) $1/3$
- (3) $1/\sqrt{3}$
- (4) $\sqrt{3}$
- (5) 3
- (6) 9

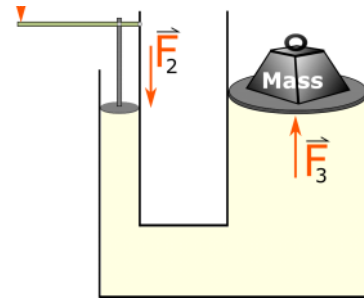

(b) If the area of the larger piston is 9.42 m^2 , what should be the radius of the smaller piston so that the hydraulic mechanical advantage is 3?

(c) As the picture is drawn, what is the mechanical advantage of the total system?

- (1) Greater than 3
- (2) Less than 3
- (3) Equal to 3

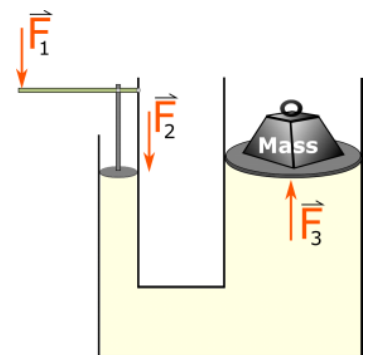

Act II: Buoyancy

FS.2.L2-6:

Description: Proportional reasoning with ideal gas law. (2 minutes + 4 minutes)

Learning Objectives: [1, 12, 13]

Problem Statement: Consider a person standing on the level ground near the surface of the earth. Which one of the FBD correctly describe the forces acting on the person?

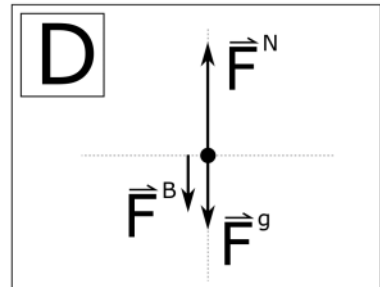
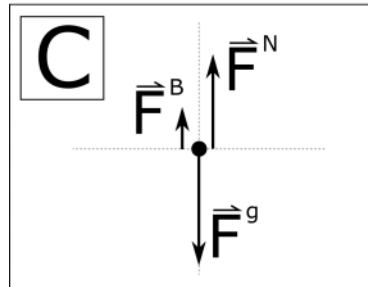
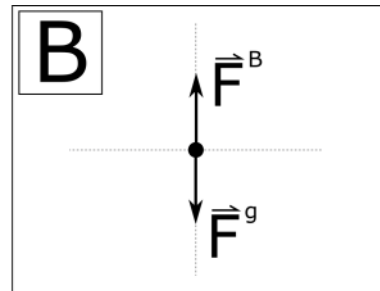
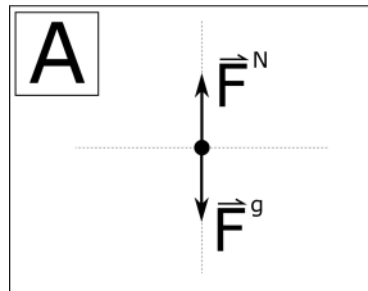

FS.2.L2-7:

Description: Determine signs of first law quantities. (5 minutes)

Learning Objectives: [1, 12, 13]

Problem Statement: Consider two identical blocks in a beaker of water. Block 1 is suspended such that it is just barely above the surface of the bottom. Block 2 is resting on the bottom. Which block experiences a larger buoyant force?

- (1) Block 1
- (2) Block 2
- (3) Equal buoyant forces
- (4) Unable to determine without the density of water.

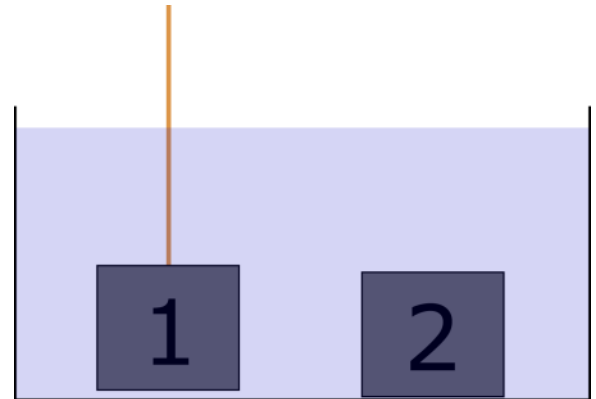

FS.2.L2-8:

Description: Identify which statements best represents an adiabatic curve on PV diagram (3 minutes)

Learning Objectives: [1, 12, 13]

Problem Statement: Two equal-sized action figures that have different masses are held by strings so that they are submerged in water at different depths.

(a) The pressure exerted on the bottom of the 3 kg mass by the water is _____ the pressure on the bottom surface of the 1 kg mass.

- (1) greater than
- (2) less than
- (3) equal to

(b) The buoyant force exerted by the water on the 3 kg mass is _____ the buoyant force on the 1 kg mass.

- (1) greater than
- (2) less than
- (3) equal to

(c) The tension in the string holding the 3 kg mass is _____ the tension in the string holding the 1 kg mass.

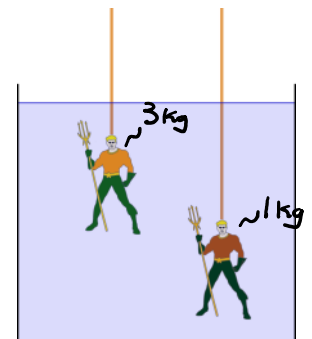

- (1) greater than
- (2) less than
- (3) equal to

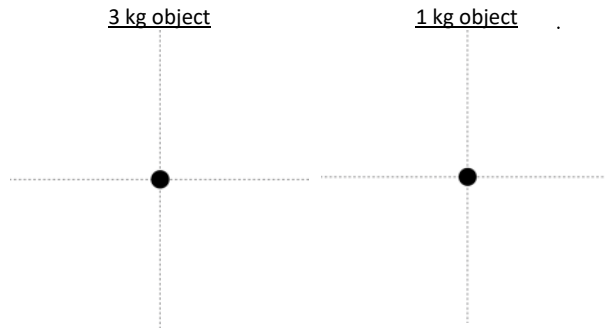

FS.2.L2-9:

Description: Identify proportionality for adiabatic process. (3 minutes)

Learning Objectives: [1, 12, 13]

Problem Statement: In each case, a block hanging from a string is suspended in a liquid. All of the blocks are the same size, but they have different masses (labeled M_b) because they are made of different materials. All of the containers have the same volume of liquid, but the masses of these liquids vary (labeled M_L) since the liquids are different. The volume of the blocks is one-sixth the volume of the liquids. Rank the buoyant forces on the blocks.

A	B	C	D
$M_b = 40 \text{ g}$ $M_L = 200 \text{ g}$	$M_b = 50 \text{ g}$ $M_L = 200 \text{ g}$	$M_b = 30 \text{ g}$ $M_L = 150 \text{ g}$	$M_b = 40 \text{ g}$ $M_L = 120 \text{ g}$

FS.2.L2-10:

Description: Determine signs of first law quantities. (5 minutes)

Learning Objectives: [1, 12, 13]

Problem Statement: Four blocks are suspended from strings in water. Blocks **A** and **C** are at the same depth, as are **B** and **D**. Rank the tensions in the strings.

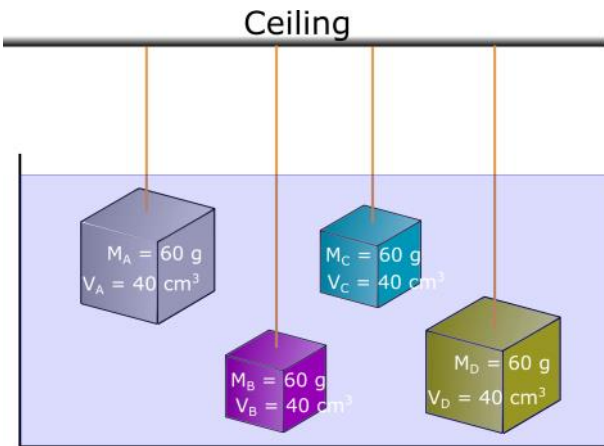

FS.2.L2-11:

Description: Sketch an isobaric process. (2 minutes)

Learning Objectives: [1, 12, 13]

Problem Statement: Consider a distant planet where the acceleration of a freely falling object (g) is greater than that on earth.

(a) Would you float more or less easily in water on this planet compared to earth? Hint: how easily we float can be quantified by looking at the ratio of your volume below the water to your total volume.

- (1) More easily
- (2) Less easily
- (3) Float the same.

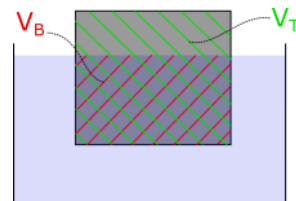

(b) If the density of the fluid is less than an object, which of the following statements are true?

- (1) $V_b/V_T = 1$; and it sinks
- (2) $V_b/V_T = 1$; and it floats
- (3) $V_b/V_T > 1$; and it sinks
- (4) $V_b/V_T > 1$; and it floats
- (5) $V_b/V_T < 1$; and it sinks
- (6) $V_b/V_T < 1$; and it floats

FS.2.L2-12:

Description: Proportional reasoning with ideal gas law. (4 minutes)

Learning Objectives: [1, 12, 13]

Problem Statement: Two cups are filled to the same level with water. One of the two cups has ice cubes floating in it. When the ice cubes melt, in which cup is the level of the water higher?

- (1) The cup without ice.
- (2) The cup with ice.
- (3) It is the same in both.

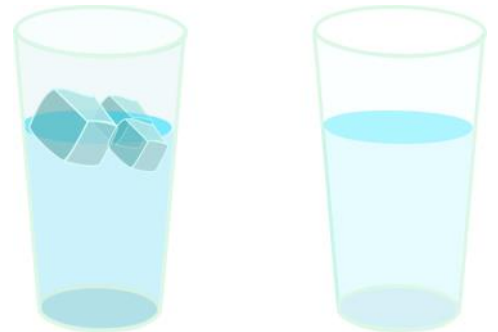

FS.2.L2-13:

Description: Determine signs of first law quantities. (5 minutes)

Learning Objectives: [1, 12, 13]

Problem Statement: A piece of gold is fastened on top of a large solid piece of Styrofoam that floats in a container of water. Because the weight of the gold, the waterline is flush with the top surface of the Styrofoam.

(a) Which of the following statements are true if the system is turned upside down so that the lead is now suspended underneath the Styrofoam?

- (1) The system sinks.
- (2) The waterline is below the top surface of the Styrofoam.
- (3) The waterline is still flush with the top surface of the Styrofoam.

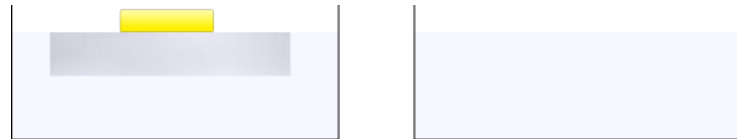

(b) The water level in the container

- (1) rises.
- (2) drops.
- (3) remains the same.

FS.2.L2-14:

Description: Determine signs of first law quantities. (5 minutes)

Learning Objectives: [1, 12, 13]

Problem Statement: Two mobsters drop a suspiciously large brick of concrete out of a boat in a large lake. Does the level of the water in the lake, relative to the shore, increase, decrease, or stay the same?

- (1) Increase.
- (2) Decrease.
- (3) Stays the same.
- (4) Depends on who's asking, are you asking?

Extreme case solution

General solution

FS.2.L2-15:

Description: Determine signs of first law quantities. (5 minutes)

Learning Objectives: [1, 12, 13]

Problem Statement: We eventually wish to determine the smallest number (N) of whole logs ($\rho_{\text{log}} = 725 \text{ kg/m}^3$, radius = 0.08 m, length = 3.0 m) that can be used to build a raft that will carry four people, each of whom has a mass of 80 kg.

(a) Draw a FBD for the raft or the raft + people system. You choose the system, there is no right or wrong system.

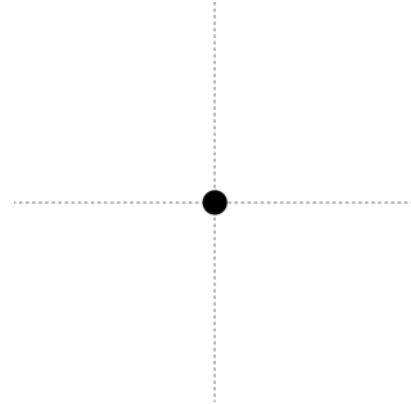
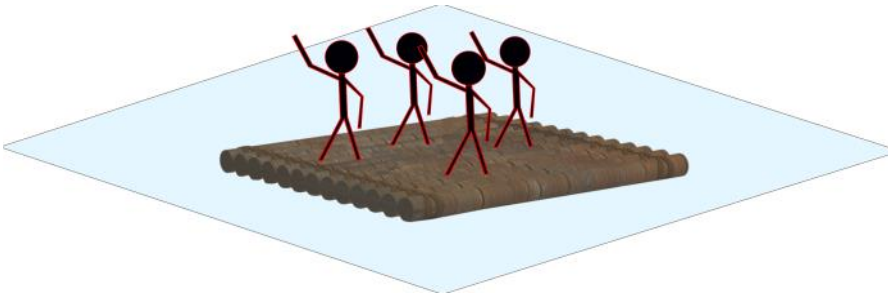

(b) Which of the following equations can be used to determine the mass of the raft?

- (1) $\rho_{\text{log}} \cdot 2 \cdot \pi \cdot r \cdot L$
- (2) $\rho_{\text{log}} \cdot N \cdot \pi \cdot r^2 \cdot L$
- (3) $\rho_{\text{log}} / N \cdot \pi \cdot r \cdot L$
- (4) $\rho_{\text{log}} / N \cdot \pi \cdot r^2 \cdot L$

(c) Which of the following equations represents the volume of the displaced water if the raft has a minimum number of logs?

- (1) V_{log}
- (2) V_{raft}
- (3) $1/2 V_{\text{log}}$
- (4) $1/2 V_{\text{raft}}$

(d) What is the smallest number (**N**) of whole logs ($\rho_{\text{log}} = 725 \text{ kg/m}^3$, radius = 0.08 m, length = 3.0 m) that can be used to build a raft that will carry four people, each of whom has a mass of 80 kg?

Conceptual questions for discussion

1. **Coming soon.**

Hints

FS.2.L1-1: No hints.

FS.2.L1-2: No hints.

FS.2.L1-3: No hints.

FS.2.L1-4: No hints.

FS.2.L1-5: No hints.

FS.2.L1-6: No hints.

FS.2.L1-7: No hints.

FS.2.L1-8: No hints.

FS.2.L1-9: No hints.

FS.2.L1-10: No hints.

FS.2.L1-11: No hints.

FS.2.L1-12: No hints.

FS.2.L1-13: No hints.

FS.2.L1-14: No hints.