

Torque

Select LEARNING OBJECTIVES:

- Define cross product and be able to demonstrate an understanding of its application through the use of the mathematical representation and physical representation.
- Define torque, and demonstrate an understanding of its functional dependence on the magnitude of a force, the moment arm, and the angle between the two.
- Understand that torque is a vector even though we only use a sign convention to describe its direction.
- Demonstrate the ability to determine the net torque on a rigid body through the use of a physical representation coupled with a mathematical representation.

TEXTBOOK CHAPTERS:

- Giancoli (Physics Principles with Applications 7th) :: 8-4, 9-4
- Knight :: 12.1, 12.5
- BoxSand :: Rotational Mechanics ([Statics & Dynamics](#))

WARM UP: Questions about rotational kinematics?

At first we studied how to describe the translational motion of objects with the quantities: position, velocity, and acceleration. Then we studied the cause of translational motion as described by Newton's laws of motion. At this point we have even looked at how to describe the motion of objects that are rotating by using the quantities: angular position, angular velocity, and angular acceleration. Now we will begin to develop a model for why objects begin to rotate or not.

It should be no surprise to you that a force must be applied to an object in order to get the object to start rotating. However, the location of the applied force, and the angle of the applied force also play a role in how fast the object begins to rotate. You are probably an expert at this concept already, what is the easiest way to open a door? Do you push further away or closer to the hinge, perpendicular to the door or parallel to the door? The mathematical way we deal with a force and its location on an object is via the quantity called torque. Torque is a vector and is found by taking the "cross product" (a mathematical operation) of the position from a reference axis that the force is applied and the force itself. This is mathematically written as...

$$\vec{\tau}_0^A = \vec{r}_A \times \vec{F}^A$$

"TORQUE ABOUT AXIS "0" DUE TO FORCE A"

"MOMENT ARM POINTS FROM REFERENCE AXIS "0" TO LOCATION OF FORCE A"

The magnitude of torque is...

$$|\vec{\tau}_0^A| = |\vec{r}_A| |\vec{F}^A| \sin \theta$$

...where θ is the smallest angle between the position vector and the force vector when placed tail-to-tail. It is highly recommended that you construct a vector-operation diagram to determine the angle θ .

The cross product is a mathematical operation that asks, "how perpendicular is one vector to the other?". Thus the magnitude of torque is often found in the following way...

$$|\vec{r} \times \vec{F}| = r_{\perp} |\vec{F}|$$

PERPENDICULAR COMPONENT OF \vec{r} WITH RESPECT TO \vec{F}

* NOTE: $r_{\perp} = |\vec{r}| \sin \theta$

$$|\vec{r} \times \vec{F}| = |\vec{r}| F_{\perp}$$

PERPENDICULAR COMPONENT OF \vec{F} WITH RESPECT TO \vec{r}

* NOTE: $F_{\perp} = |\vec{F}| \sin \theta$

Or a graphical representation of the above two definitions looks like...

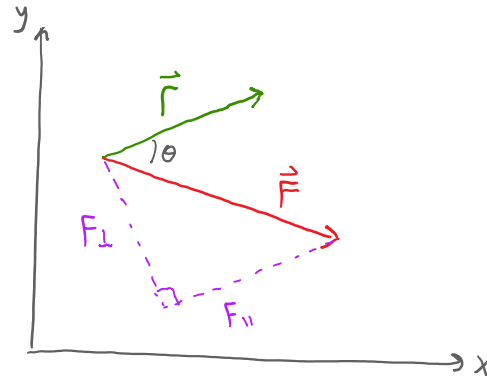
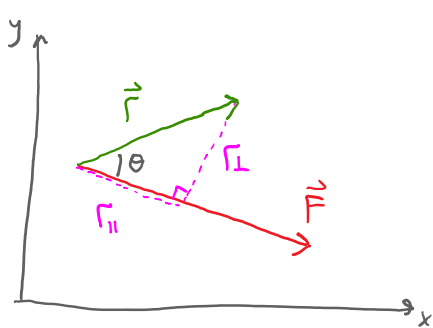

The vector nature of torque is beyond the scope of this class at the moment. However, we still need to define a rotational direction. The convention that we used in rotational kinematics is also used here. If a force is trying to rotate the object counter-clock-wise (ccw) about the axis of rotation then the torque is positive, and if a force is trying to rotate the object clock-wise (cw) about the axis of rotation then the torque is negative. The sign convention is added in by hand based on which direction the force would want the object to rotate around a chosen reference point.

$$\vec{\tau} = \vec{r} \times \vec{F}$$

$$|\vec{\tau}| = |\vec{r}| |\vec{F}| \sin \theta$$

$$\tau = \pm |\vec{r}| |\vec{F}| \sin \theta$$

ADD AD HOC BASED ON CCW (+)
CW (-)

PRACTICE: Which of the following are the dimensions of torque?

- (a) N m
- (b) $\frac{\text{kg m}^2}{\text{s}}$
- (c) $\frac{\text{kg m}}{\text{s}}$
- (d) $\frac{\text{kg m}^2}{\text{s}^2}$
- (e) $\frac{[M][L]^2}{[T]^3}$
- (f) $\frac{[M]^2[L]}{[T]^2}$
- (g) $\frac{[M][L]}{[T]^2}$
- (h) $\frac{[M][L]^2}{[T]^2}$

EXAMPLE: The figure below shows a force with a magnitude of (10 N) applied in several different ways to a 4.0 m long bar. The reference axis is labeled as "o". Rank the magnitude torque due to the applied force in each case.

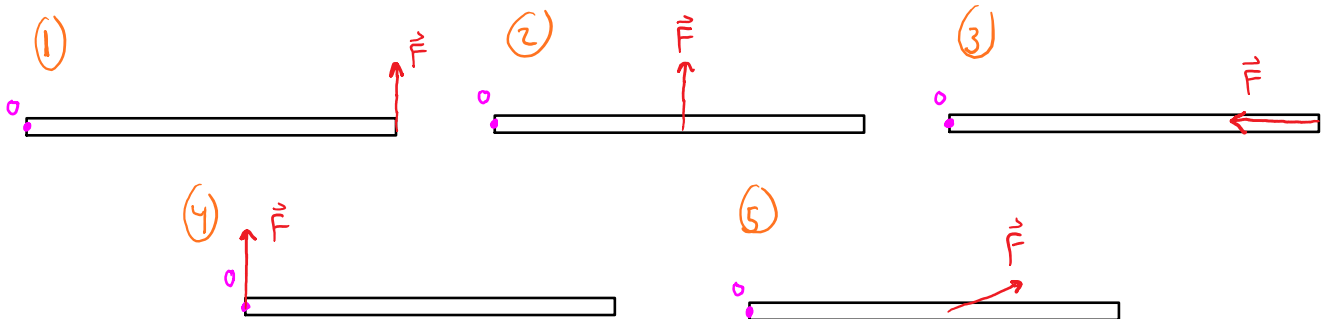

$$|\vec{\tau}_o| = |\vec{r}| |\vec{F}| \sin \theta$$

$$|\vec{\tau}_1| = L |\vec{F}| \quad |\vec{\tau}_2| = \frac{L}{2} |\vec{F}| \quad |\vec{\tau}_3| = L |\vec{F}| \sin(180) = 0 \quad |\vec{\tau}_4| = 0 |\vec{F}| = 0 \quad |\vec{\tau}_5| = \frac{L}{2} F_{\perp}$$

$F_{\perp} < |\vec{F}|$

$$|\vec{\tau}_1| > |\vec{\tau}_2| > |\vec{\tau}_5| > |\vec{\tau}_3| = |\vec{\tau}_4| = 0$$

PRACTICE: The figure below shows a force with a magnitude of (10 N) applied in several different ways to a 5.0 m long bar. The reference axis is labeled as "o". Rank the torque due to the applied force in each case from most negative to most positive.

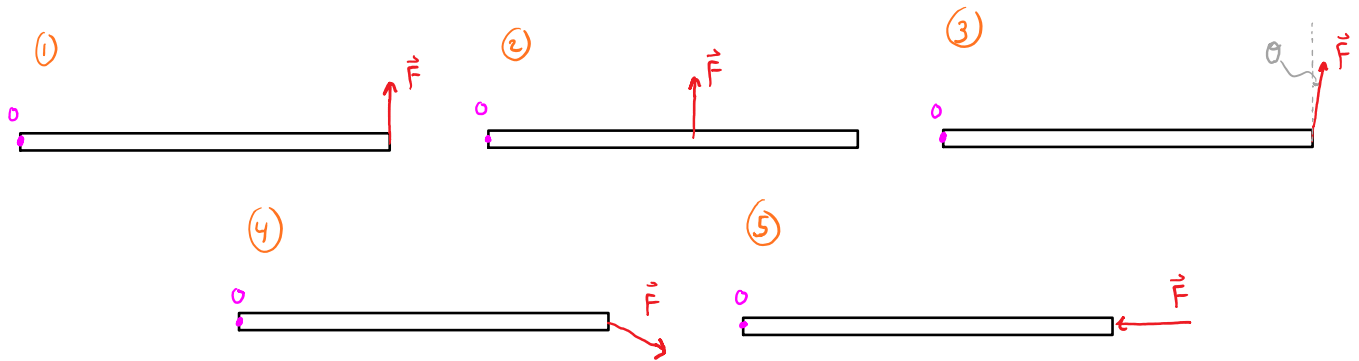

PRACTICE: Rank in order, from largest to smallest, the five magnitudes of torques about the reference axis labeled "o". The bars all have the same length.

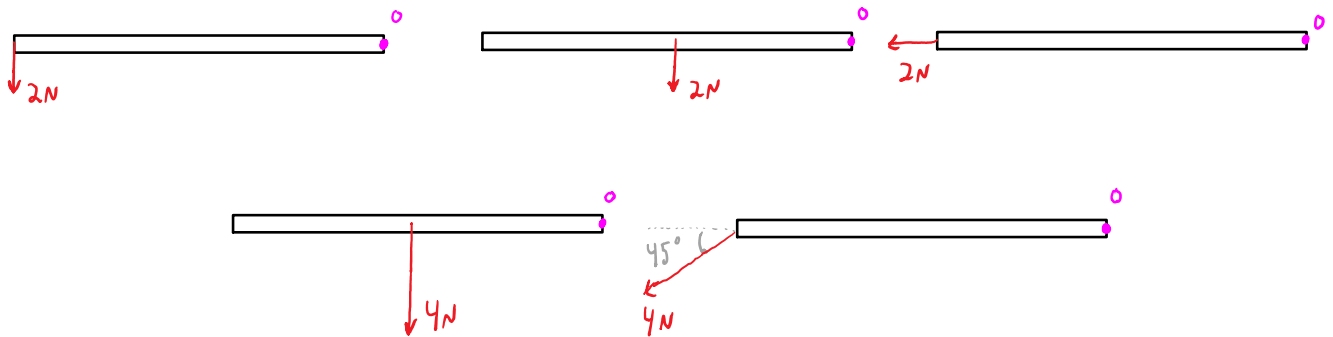

PRACTICE: Calculate the torque, in $\text{N}\cdot\text{m}$, about the nut from the applied force in the figure below.

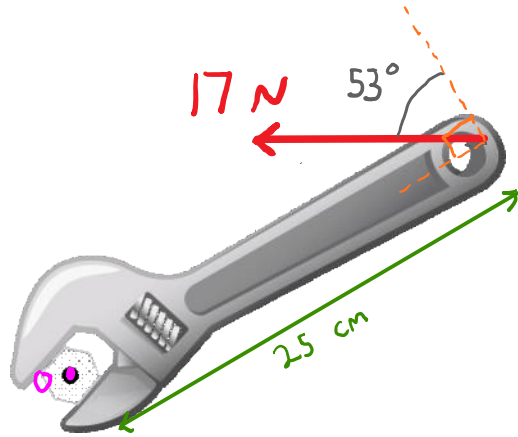

Our goal is to eventually get to a model that helps us analyze the cause of rotational motion. For translational motion, a net force acting on an object resulted in an acceleration of the center of mass of the object; this is Newton's 2nd law. As it turns out we can also formulate Newton's 2nd law for rotational motion: the net torque on an object results in an angular acceleration. We will study this statement more carefully in the next lecture, but now that you have a feeling for where we are headed, you will be pleased that the analysis tools used for this rotational version of Newton's 2nd law are very similar to what you have been using for the translational model. Thus, I would first like to work on our physical representation for rotational mechanics: the "extended free body diagram (e-FBD)".

Extended free body diagram (e-FBD)

Our first step when analyzing causes of rotational motion is the same as before, define your system! On a picture of the scenario, draw a dashed line around the object(s) you which to study. Once the system is defined we will draw an e-FBD. The e-FBD should include the physical shape of the object you chosen as your system, all of the forces acting on this object with their tails at the location where the force acts, a labeled reference axis, moment arms, coordinate system, and any relevant angles. Remember, we are only interested in forces acting on our system; your e-FBD should not include the physical shape of other objects that are not a part of your system.

Notice that our process of defining a system and looking at external forces is the same as the translational counterpart we have been studying so far. This means that a regular FBD will have the same forces (no more, no less, no different forces), as an e-FBD for the same system. If you are having trouble with e-FBDs, consider drawing a regular FBD first since it is probably more familiar at this point. Once the FBD is drawn, you can go back to your e-FBD to check if you identified all the external forces.

A quick note before we begin. If we have a single object of mass M in our system, at what location does the force of gravity act? The total mass of the object is distributed over some shape, thus little sections of the object have little masses m which the force of gravity acts on. So it seems the answer to this question of location is, the force of gravity acts over the entire object (break the object M into many tiny

"point particles" of mass m and the force of gravity " mg " acts at each of these locations). This is not very useful at the moment, after all, how are we supposed to draw a vector at every location that the object exists? Luckily, the net effect of gravity acting on all locations of the object can be replaced with 1 force of gravity acting on the total mass M at the center of mass of the object. We will work with center of mass in the next lecture, but for now all you need to know is if an object's mass is "uniformly distributed", the center of mass is at the geometric center of the object. In general, the location where the force of gravity seems to act on is not necessarily always at the center of mass of an object, thus it is given a special name, the center of gravity. We will not study any of these scenarios in this class. Since we are restricting ourselves to scenarios where the center of mass is at the same location of the center of gravity we often use the terms interchangeably. But be careful when communicating with others outside of class or reading articles, the center of mass and the center of gravity may not coincide.

EXAMPLE: Draw an e-FBD for m_1 in the picture below.

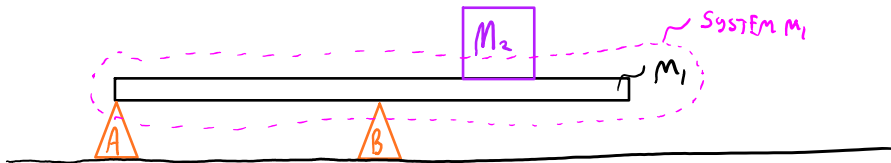

PRACTICE: Draw an e-FBD for m_1 in the picture below.

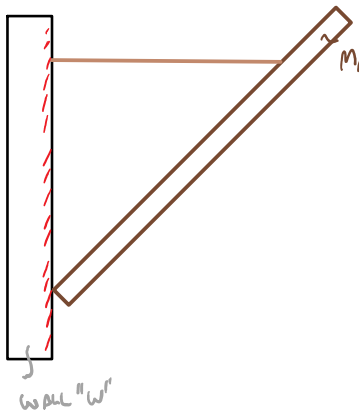

PRACTICE: Draw an e-FBD for m_1 in the picture below.

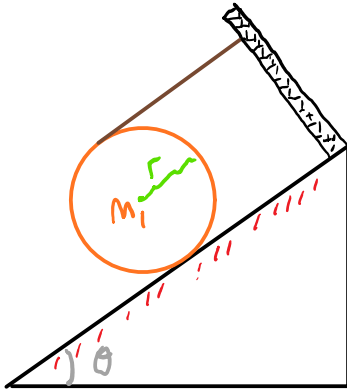

Questions for discussion:

- (1) A friend of yours claims that it is easiest to open a door by pushing at a location furthest away from the hinge. Do you agree? Would you add anything to this statement?
- (2) How might you experimentally find the center of gravity for an object?